

# FORCE USA

## F-X15-V2 ALL-IN-ONE TRAINER

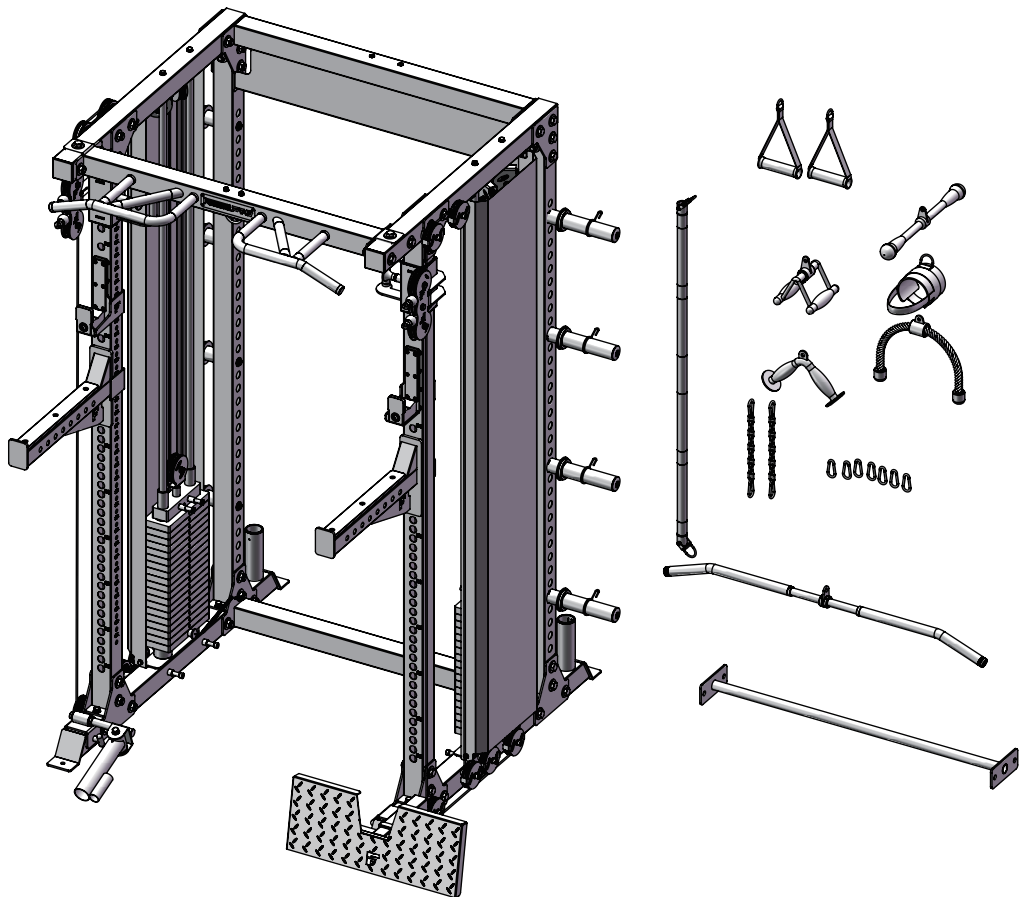

# TABLE OF CONTENTS

SECTION	PAGES
Before you Start and Safety Information .....	2
ForceUSA App .....	3
Preventative Maintenance .....	4
Parts Identification.....	5-12
Assembly Steps .....	13-30
Exploded Diagrams .....	31-49
Parts Lists .....	50-53
Warranty Information .....	54

# USER MANUAL

## Before You Start

- Read all instructions in this manual before assembling or using this equipment
- Remove all parts from the packaging and count each component separately to ensure everything is provided correctly, noting that some items may be pre-assembled
- Follow the instructions and refer to both the individual assembly pages and the exploded views of the equipment whenever possible
- The owner is responsible for ensuring that all users of this unit have read the user manual and understand the safety precautions
- Descriptions of left and right refer to the perspective of standing in front of the equipment
- Place all parts in a cleared area and remove the packing materials. Do not dispose of the packing materials until all assembly steps are completed
- Machines with a counterbalanced smith bar require up to one meter of clearance above the assembled height to insert the counterbalances. If there is not enough clearance, insert the counterbalances into the required framing components before assembly and securely anchor off the cables to ensure they can be retrieved and attached as needed
- It is recommended to keep these instructions

## Safety Precautions

- **IMPORTANT: Only tighten nuts and bolts loosely until all equipment is assembled. Once the equipment is fully assembled each bolt can be tightened working evenly around the equipment where possible**
- It is highly recommended that two or more people are used for assembly
- Assemble equipment on a flat surface
- Consider placing a mat/mats under the equipment to protect your floor
- Ensure all parts are in working order prior to use
- Make sure all pivoting components are able to move freely
- Do not use or store the equipment outdoors or around water
- Do not over tighten any component with pivoting function
- Keep hair, fingers and clothing away from moving parts
- Only use attachments recommended by the manufacturer
- Never operate if parts are not functioning correctly
- Always stretch prior to using equipment
- Stop immediately if you experience any pain, dizziness or nausea
- Before starting any exercise program consult your doctor

# FORCE USA TRAINING APP

The Force USA training app offers programs, tutorials, progress tracking and more. Not compatible with all Force USA equipment.



# PREVENTATIVE MAINTENANCE

To ensure your equipment is operating at its peak, please follow the below preventative maintenance schedule performing all tasks upon initial assembly:

## Daily Maintenance

- Wipe down the equipment to remove any dust and sweat residue with a dry, non-abrasive cloth
- Inspect the unit for noisy, damaged or loose components



## Monthly Maintenance

- Thoroughly clean the equipment using a non abrasive cloth dampened with a mild, all purpose cleaner ensuring to thoroughly wipe down and dry the equipment afterwards
- Apply a 100% silicone lubrication (preferably spray) to guide rods, pulley sliders, weight plate carriages and any other moving parts where friction can occur including bearings (where applicable). Any other form of lubrication will void your warranty
- Check the tightness of all bolts, nuts and screws
- Check the cables for fraying or any signs of wear and ensure they are at the correct tension with a small amount of slack at resting position (where applicable)
- Inspect pulleys for any damage or cracks (where applicable)
- Knurling can be cleaned using a soft bristled brush to help remove any particles that may be nestled within the knurling
- Vacuum around the machine/equipment to prevent dust acclimation

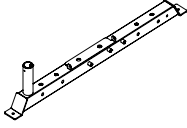
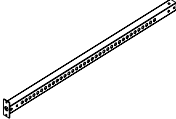
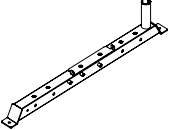
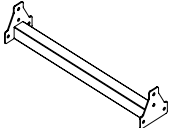
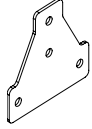
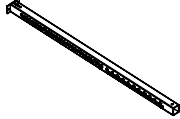
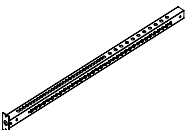
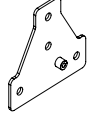
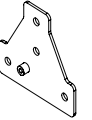
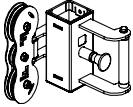
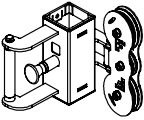

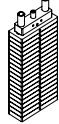

# PARTS IDENTIFICATION

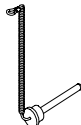
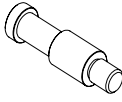
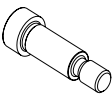
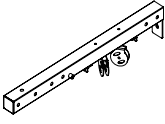
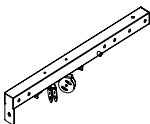
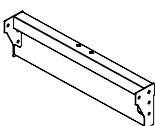
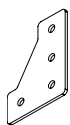
Key No.	Description	Quantity	Parts Schematic Diagram
1	Base Frame - Left	1	
2	Rear Upright	2	
6	Base Frame - Right	1	
7	Rear Base Frame	1	
8	Rear Base Fixing Plate	4	
12	Front Upright - Left (silver)	1	
13	Front Upright - Right (silver)	1	
14	Front External Base Fixing Plate - Left	1	
15	Front External Base Fixing Plate - Right	1	
16	Pulley Slider - Left	1	
17	Pulley Slider - Right	1	

# PARTS IDENTIFICATION

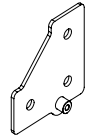
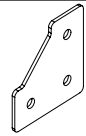
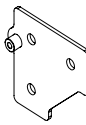
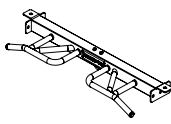

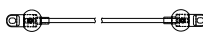
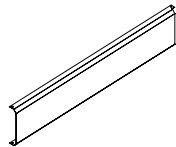
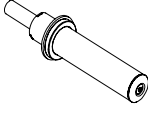
Key No.	Description	Quantity	Parts Schematic Diagram
18	Weight Stack Guide Rod	4	
19	Weight Stack (Includes Top Weight Plate)	2	
20	Weight Stack Pulley Frame	2	
21	Rubber Bumper - Weight Stack	4	
22	Weight Stack Selector Pin	2	
23	Weight Stack Locking Shaft	4	
24	Internal Hex Column Screw	4	
27	Upper Frame - Right	1	
29	Upper Frame - Left	1	
30	Logo Board	1	
31	Rear External Top Fixing Plate	2	

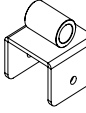
# PARTS IDENTIFICATION



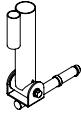
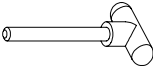
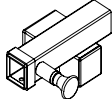
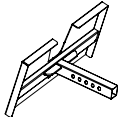
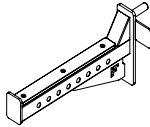
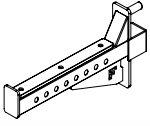
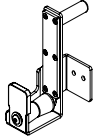
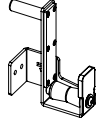
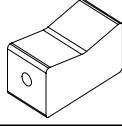
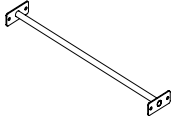

Key No.	Description	Quantity	Parts Schematic Diagram
32	Front External Top Fixing Plate - Left	1	
33	Front Internal Top Fixing Plate	2	
34	Front External Top Fixing Plate - Right	1	
35	Chin Up Frame	1	
36	Pulley Cover	12	
37	Pulley (96mm)	16	
42	Weight Stack Cable	2	
43	External Weight Stack Shield	2	
46	Plate Storage Horn	8	
47	Spring Collars	8	
50	Core Trainer Bracket	1	

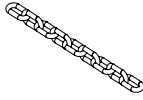

# PARTS IDENTIFICATION

Key No.	Description	Quantity	Parts Schematic Diagram
51	Core Trainer	1	
52	T-Shaped Pin	2	
53	Low Row Foot Plate Support Frame	1	
54	Low Row Foot Plate	1	
55	Front Safety - Right	1	
56	Front Safety - Left	1	
57	J-Hook - Right	1	
58	J-Hook - Left	1	
59	J-Hook Flat Shock Pad	2	
60	Horizontal Bar	1	
61	Single Stirrup - Nylon	2	

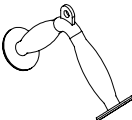
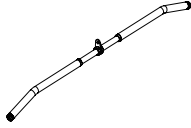
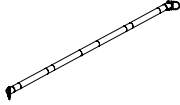
# PARTS IDENTIFICATION

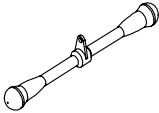
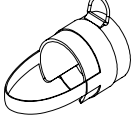
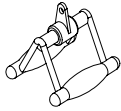
Key No.	Description	Quantity	Parts Schematic Diagram
62	Extension Chain	2	
63	Carabiner	11	
64	V Bar	1	
65	Lat Pull Down Bar	1	
66	Connection Bar -Straight	1	
67	Tricep Rope	1	
68	Short Straight Bar	1	
69	Ankle Cuff	1	
70	Close Grip Triangle	1	

# PARTS IDENTIFICATION

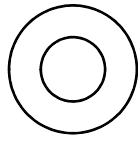

45.  $\phi$  8 Flat Washer 8PCS

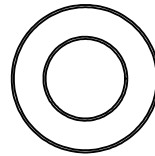

25.  $\Phi$  10 Flat Washer 24PCS

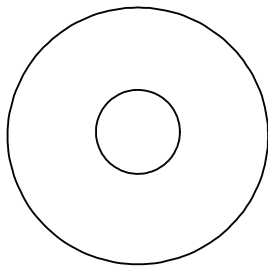

48.  $\phi$  10 Big Flat Washer 8PCS

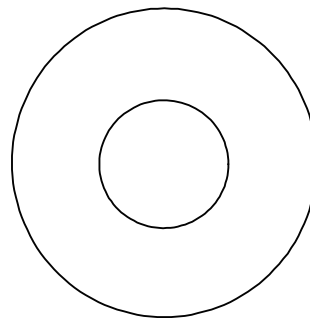

10.  $\phi$  17 $\times$   $\phi$  40 $\times$ 3 Flat Washer 74PCS

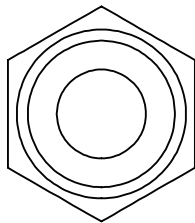

M16 Lock Nut 36PCS

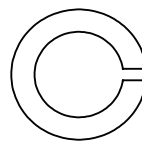

$\phi$  10 Spring Washer 12PCS

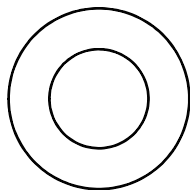

4.  $\phi$  12 Flat Washer 8PCS

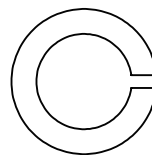

5.  $\phi$  12 Spring Washer 8PCS

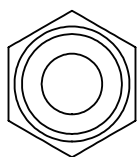

40.M10 Lock Nut 4PCS

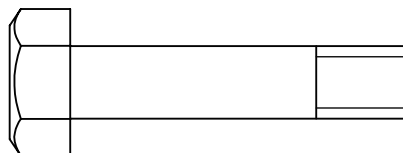

39.M10 $\times$ 45 Hexagon Bolt 4PCS

# PARTS IDENTIFICATION

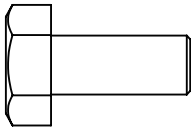

44.M8×16 Hexagon Bolt 8PCS

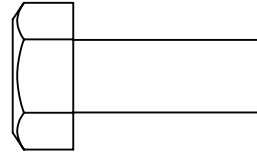

49.M10×25 Hexagon Bolt 8PCS

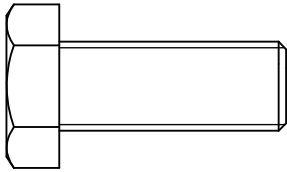

3.M12×25 Hexagon Bolt 8PCS

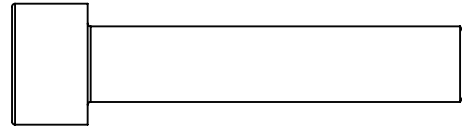

24.M10×50  
Inner Hexagon Column Screw 12PCS

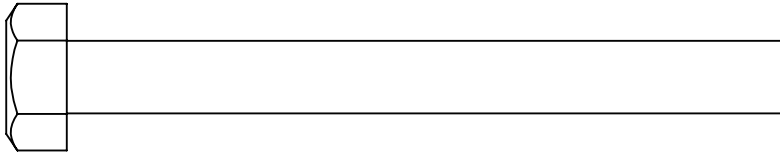

6.M10×95 Hexagon Bolt 4PCS

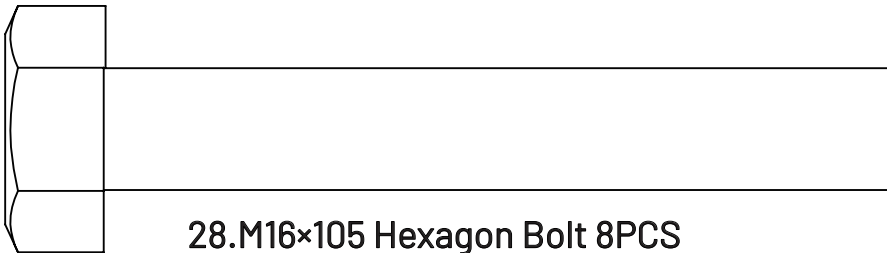

28.M16×105 Hexagon Bolt 8PCS

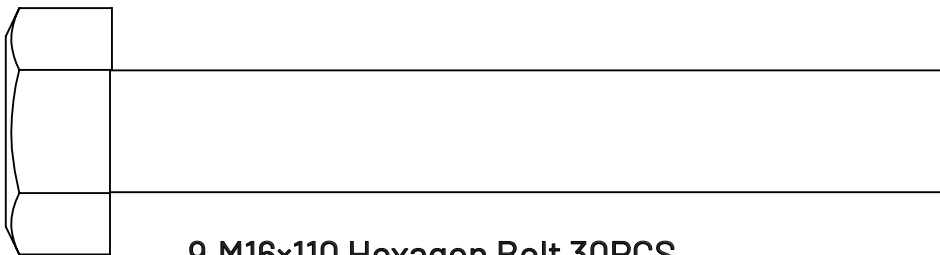

9.M16×110 Hexagon Bolt 30PCS

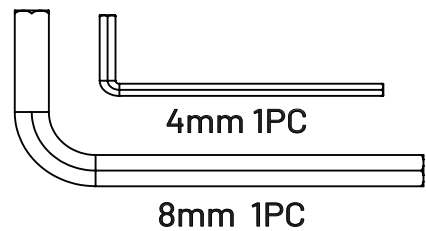
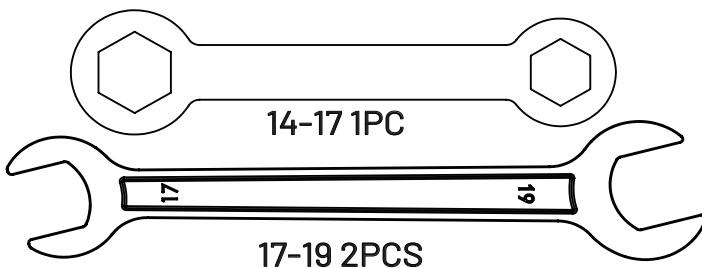

# PARTS IDENTIFICATION

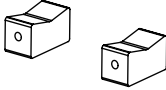

59.J-Hook Flat Shock Pad 2pcs

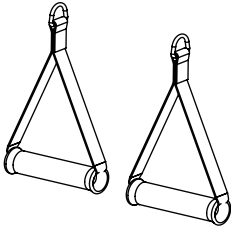

61.Single Stirrup - Nylon 2pcs

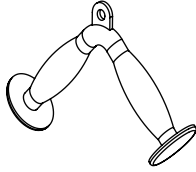

64.V-bar 1pcs

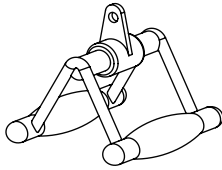

70.Close Grip Triangle 1pcs

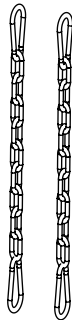

62.Extension Chain 2pcs

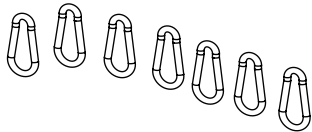

63.Carabiner 11pcs



66.Connection Bar -Straight 1pcs

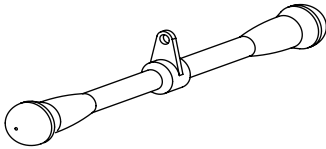

68.Short Straight Bar 1pcs

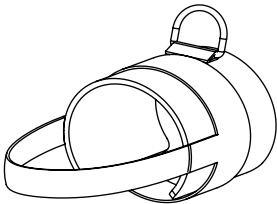

69.Ankle Cuff 1pcs

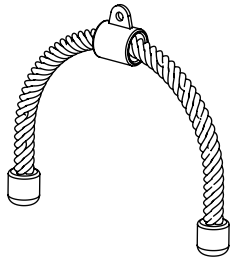

67.Tricep Rope 1pcs

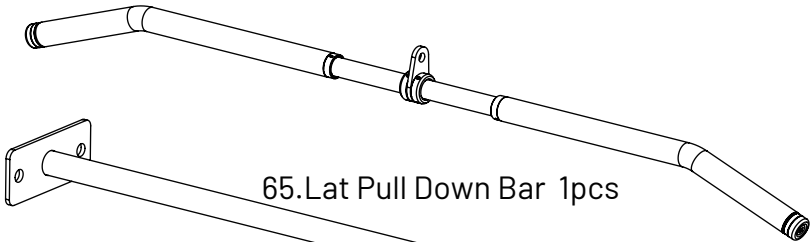

65.Lat Pull Down Bar 1pcs

(60) Horizontal Bar 1pcs

# ASSEMBLY STEP 1

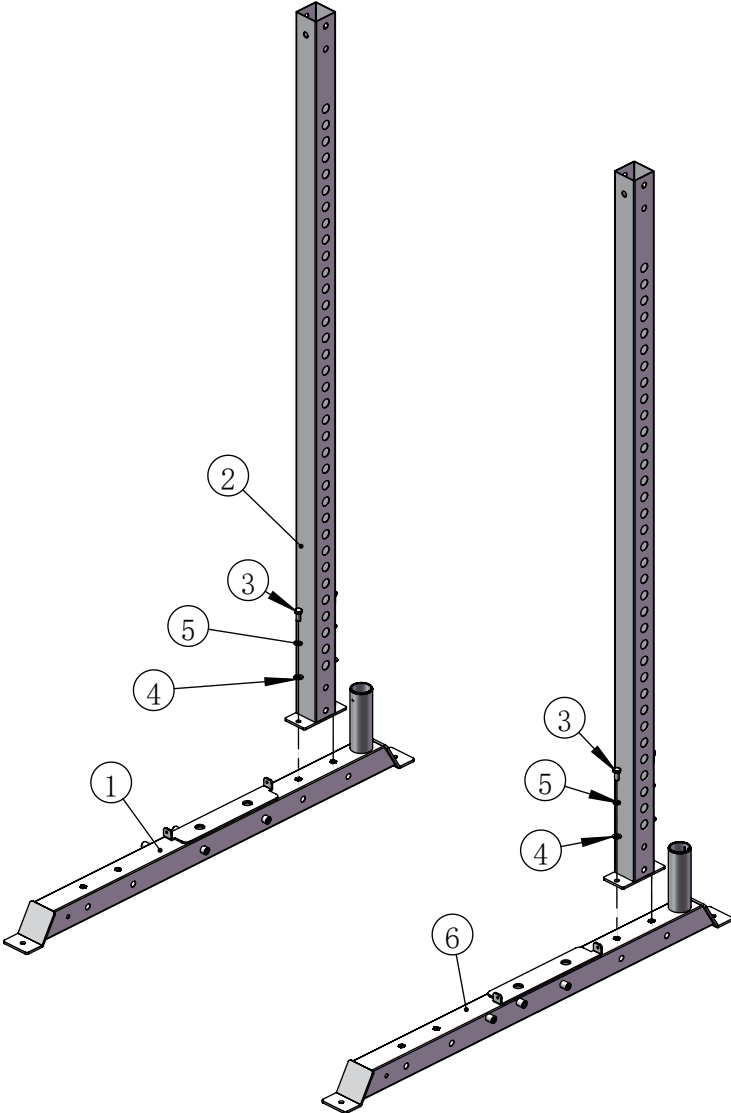

Key No.	Description	Note	Quantity
1	Base Frame - Left		1
2	Rear Upright		2
3	Hexagon Bolt	M12×25	4
4	Flat Washer	φ12	4
5	Spring Washer	φ12	4
6	Base Frame - Right		1

# ASSEMBLY STEP 2

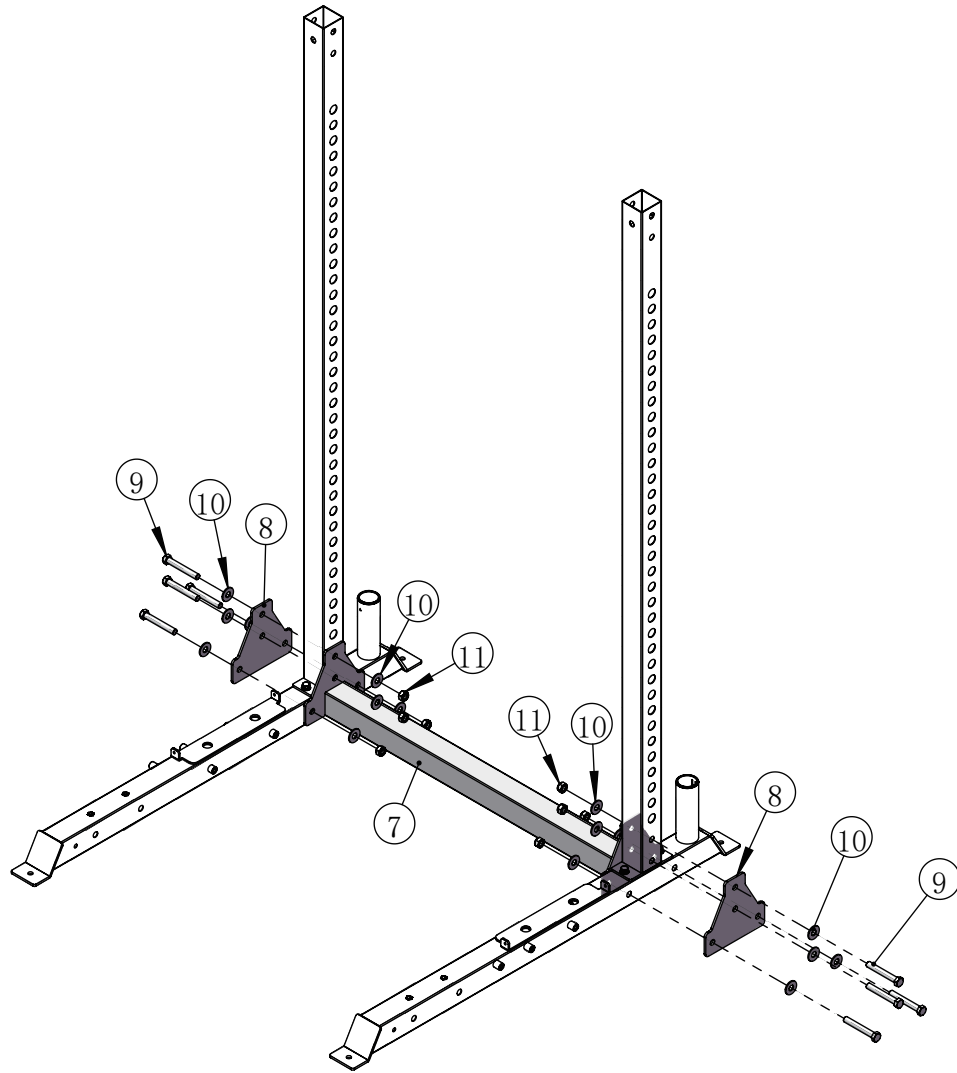

Key No.	Description	Note	Quantity
7	Rear Base Frame		1
8	Rear Base Fixing Plate	T6	2
9	Hexagon Bolt	M16×110	8
10	Flat Washer	φ17×φ40×3	16
11	Lock Nut	M16	8

# ASSEMBLY STEP 3

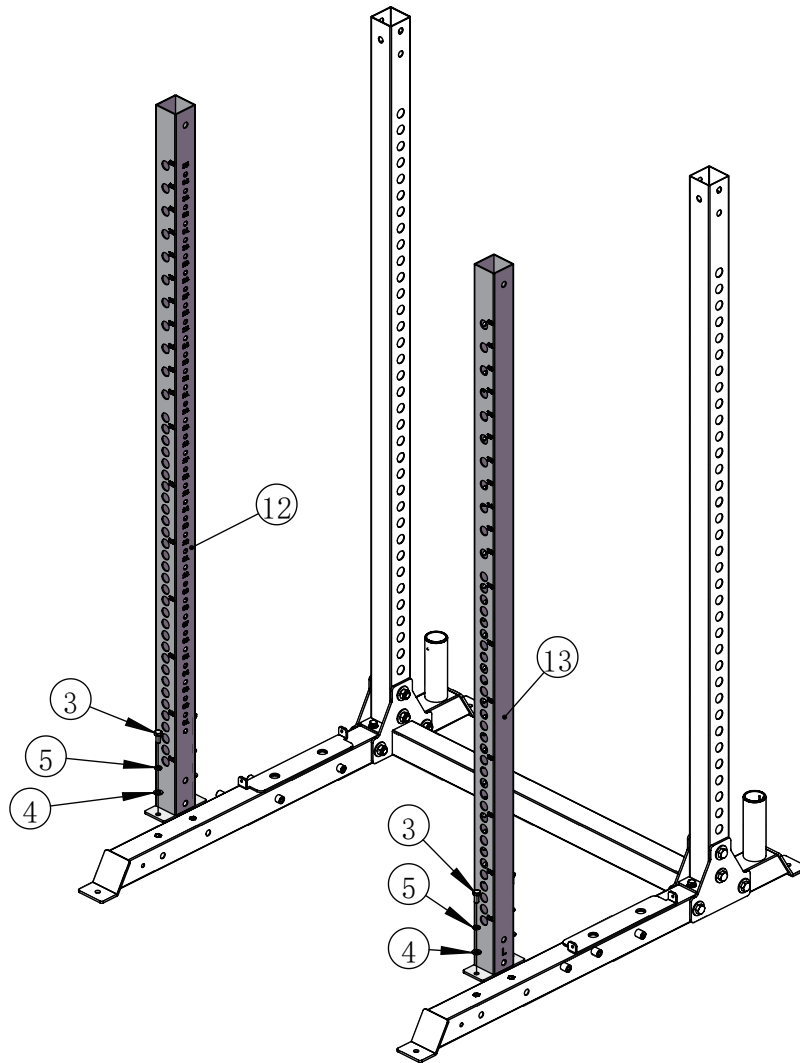

Key No.	Description	Note	Quantity
3	Hexagon Bolt	M12×25	4
4	Flat Washer	φ12	4
5	Spring Washer	φ12	4
12	Front Upright - Left (silver)		1
13	Front Upright - Right (silver)		1



# ASSEMBLY STEP 4

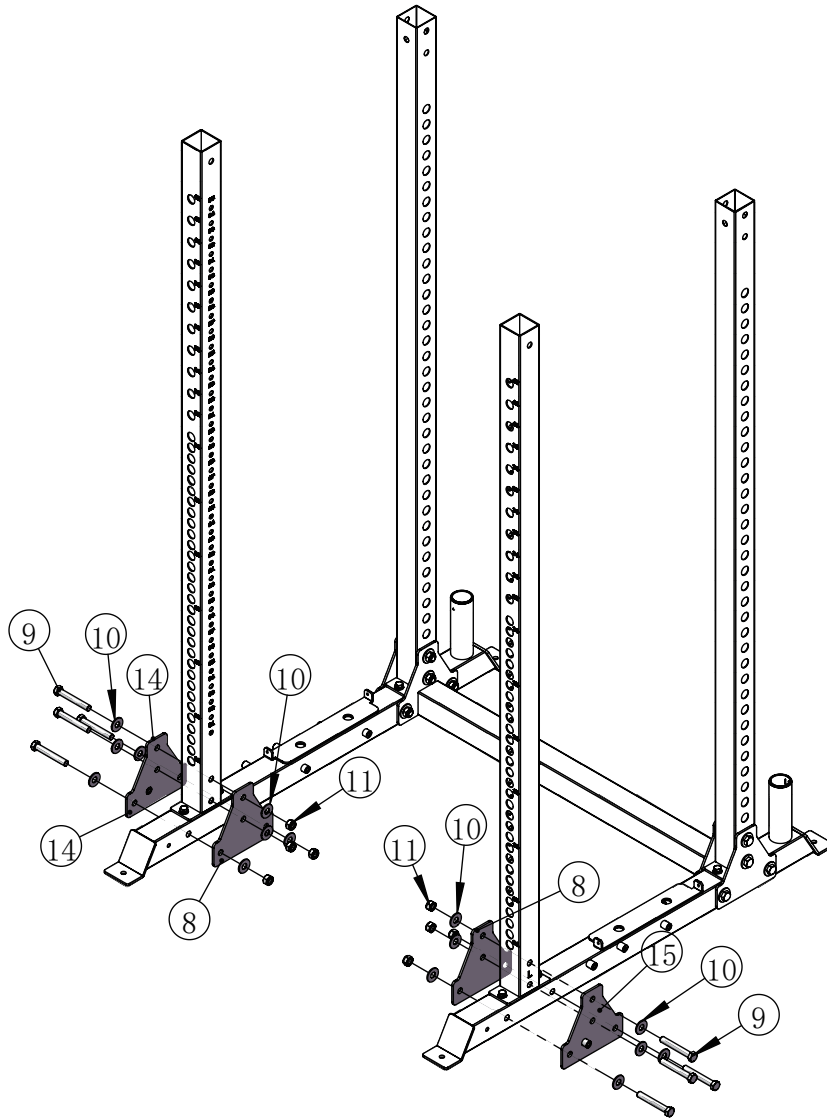

Key No.	Description	Note	Quantity
8	T-shaped Fixing Plate	T6	2
9	Hexagon Bolt	M16×110	8
10	Flat Washer	φ17×φ40×3	16
11	Lock Nut	M16	8
14	Front External Base Fixing Plate - Left		1
15	Front External Base Fixing Plate - Right		1

# ASSEMBLY STEP 5

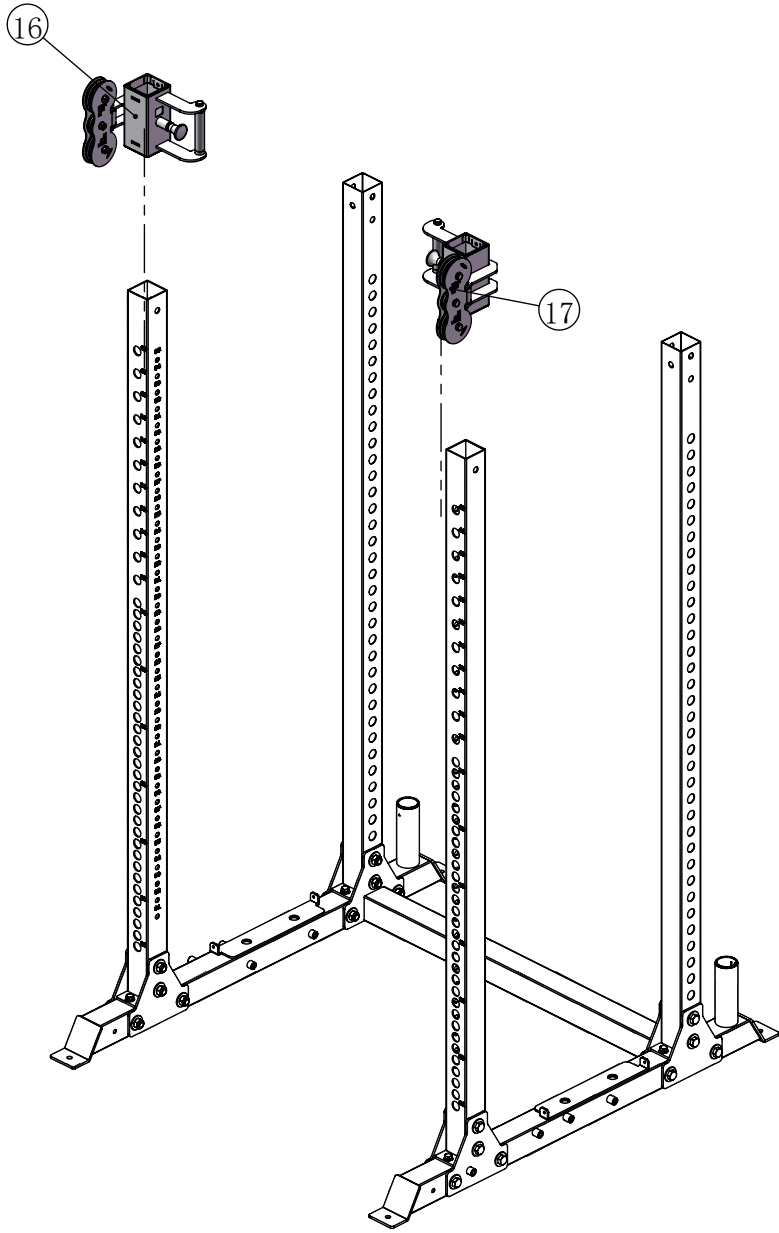

Key No.	Description	Note	Quantity
16	Pulley Slider - Left		1
17	Pulley Slider - Right		1

# ASSEMBLY STEP 6

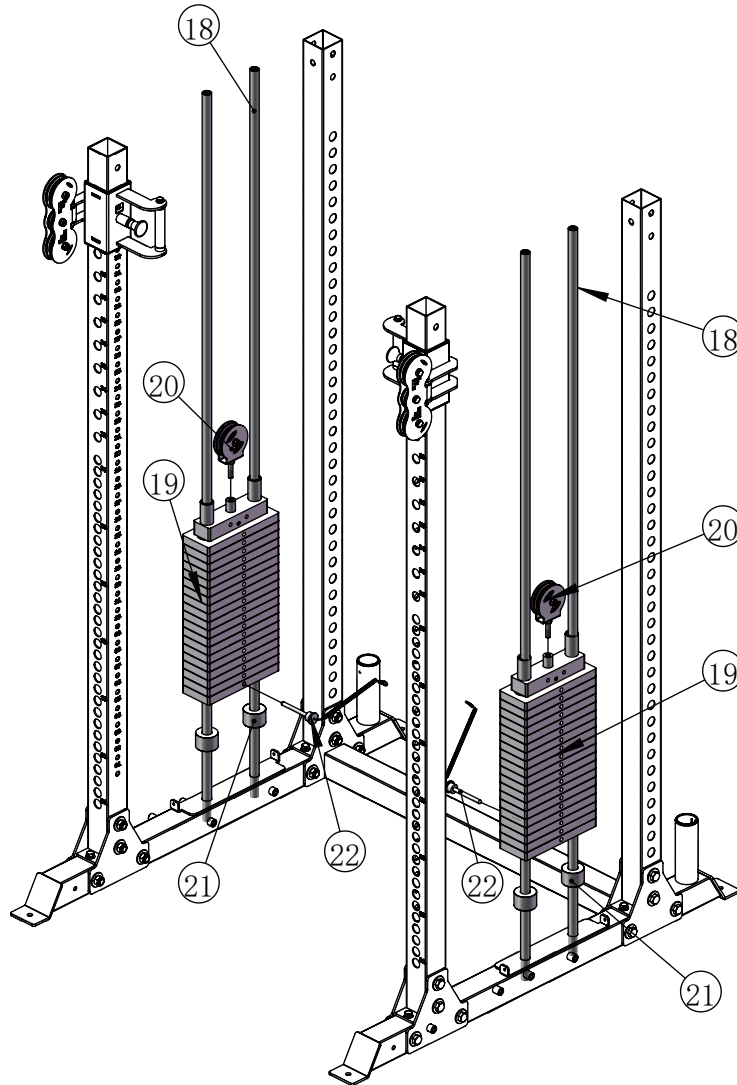

Key No.	Description	Note	Quantity
18	Weight Stack Guide Rod		4
19	Weight Stack (Includes Top Weight Plate)		2
20	Weight Stack Pulley Frame		2
21	Rubber Bumper - Weight Stack	$\phi 60 \times \phi 27 \times 42$	4
22	Weight Stack Selector Pin	$\phi 10 \times 100$	2

# ASSEMBLY STEP 7

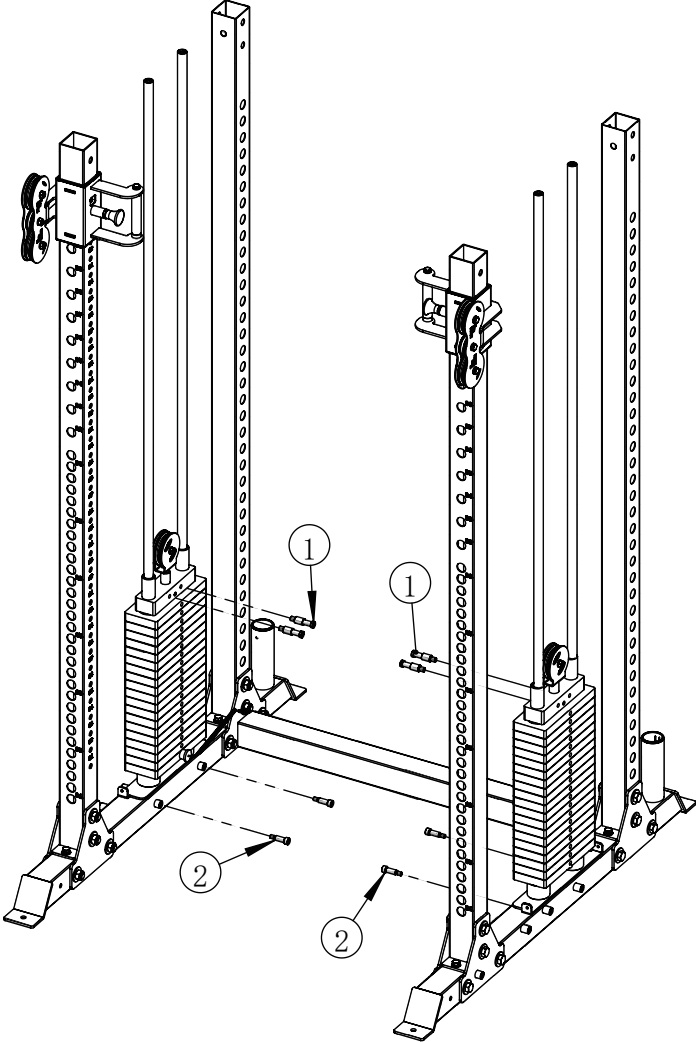

Key No.	Description	Note	Quantity
23	Weight Stack Locking Shaft	$\phi 17.8 \times 17 - M12$	4
24	Internal Hex Column Screw	$13 \times 30 - M10$	4

# ASSEMBLY STEP 8

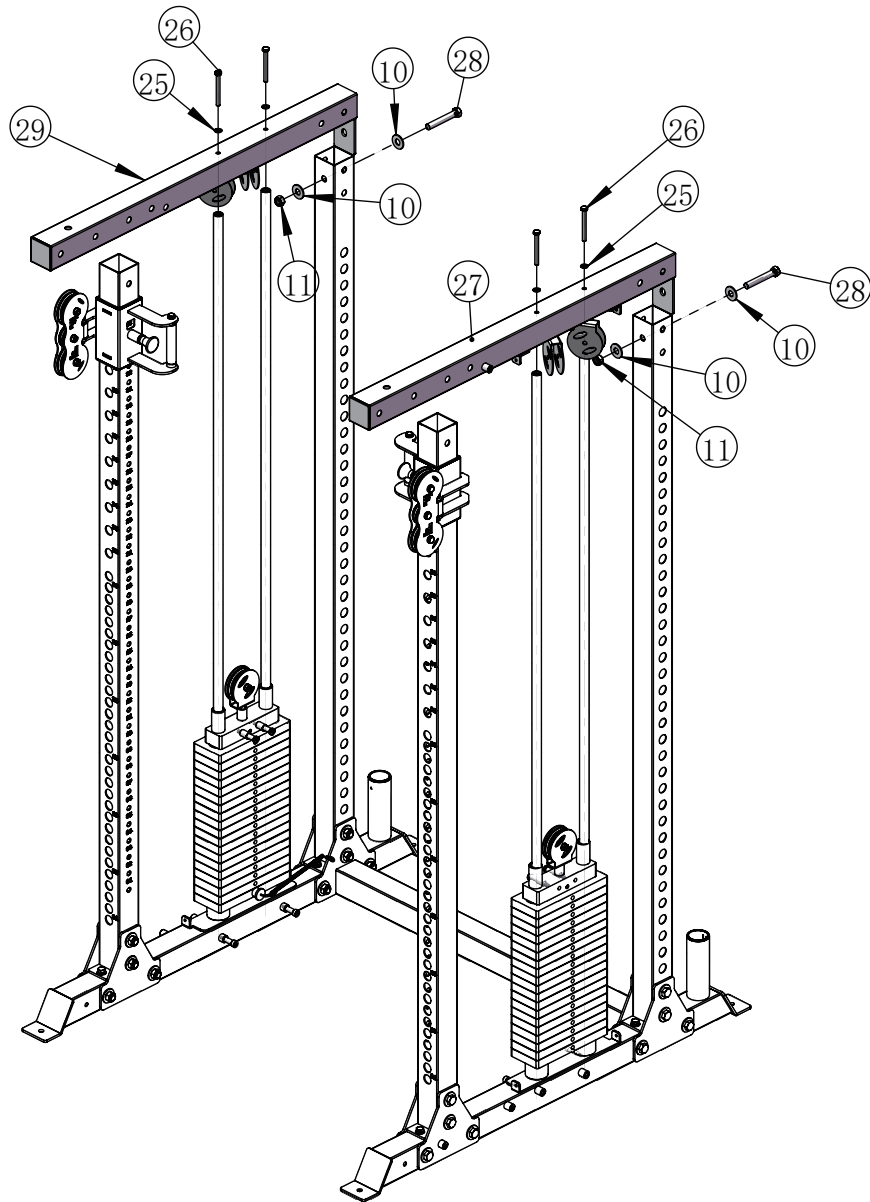

Key No.	Description	Note	Quantity
10	Flat Washer	$\phi 17 \times \phi 40 \times 3$	4
11	Lock Nut	M16	2
25	Flat Washer	$\phi 10$	4
26	Hexagon Bolt	M10 $\times$ 95	4
27	Upper Frame - Right		1
28	Hexagon Bolt	M16 $\times$ 105	2
29	Upper Frame - Left		1

# ASSEMBLY STEP 9

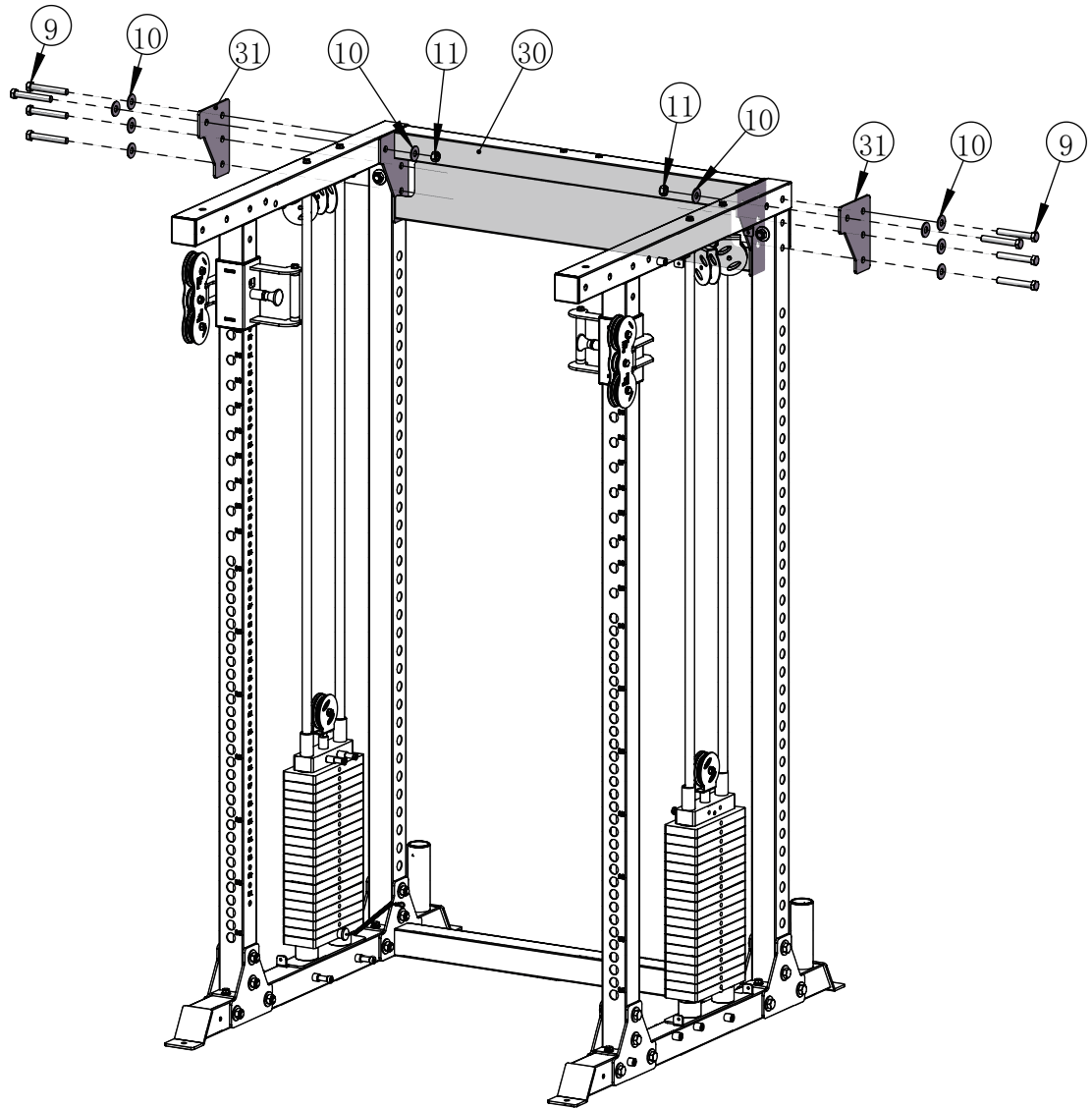

Key No.	Description	Note	Quantity
9	Hexagon Bolt	M16×110	8
10	Flat Washer	φ17×φ40×3	14
11	Lock Nut	M16	6
30	Logo Board		1
31	Rear External Top Fixing Plate	T6	2

# ASSEMBLY STEP 10

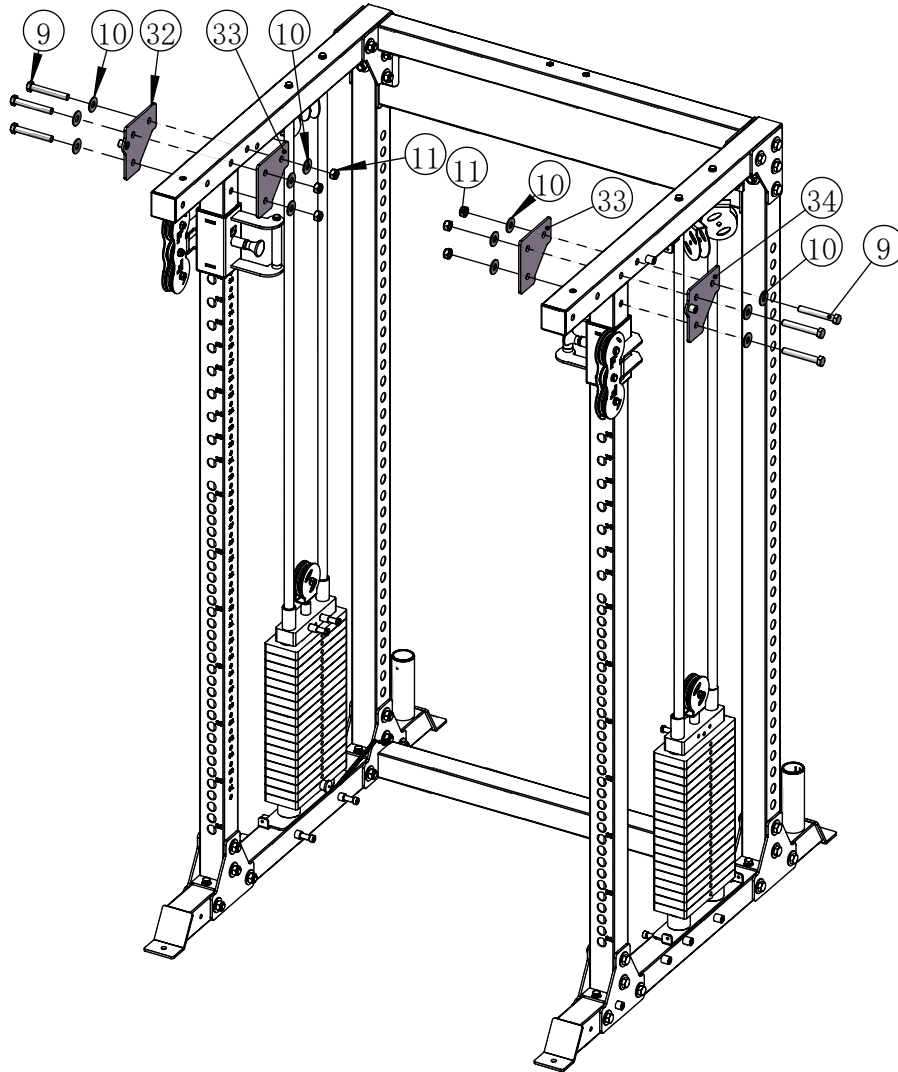

Key No.	Description	Note	Quantity
9	Hexagon Bolt	M16×110	6
10	Flat Washer	φ17×φ40×3	12
11	Lock Nut	M16	6
32	Front External Top Fixing Plate - Left		1
33	Front Internal Top Fixing Plate	T6	2
34	Front External Top Fixing Plate - Right		1

# ASSEMBLY STEP 11

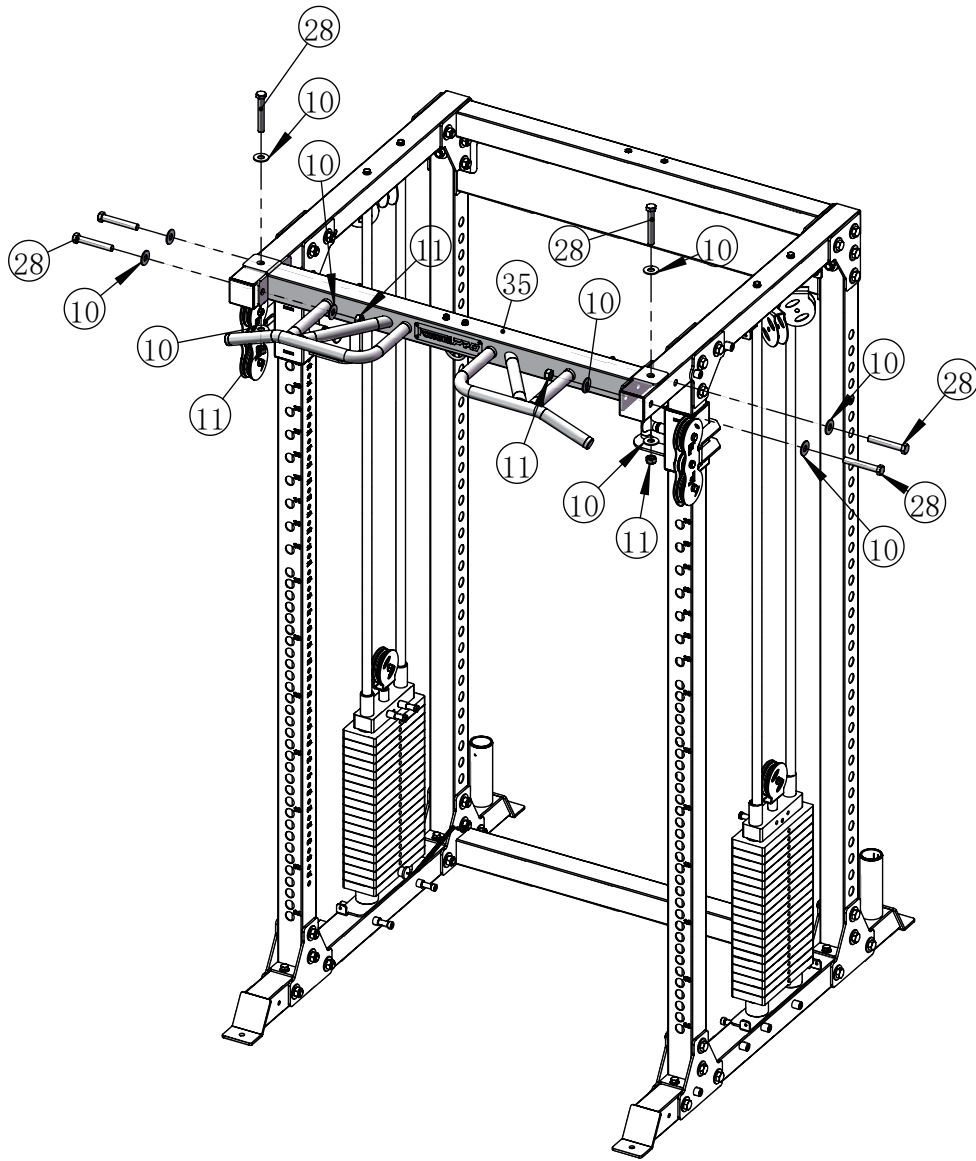

Key No.	Description	Note	Quantity
10	Flat Washer	$\phi 17 \times \phi 40 \times 3$	12
11	Lock Nut	M16	6
28	Hexagon Bolt	M16×105	6
35	Chin Up Frame		1



# ASSEMBLY STEP 12

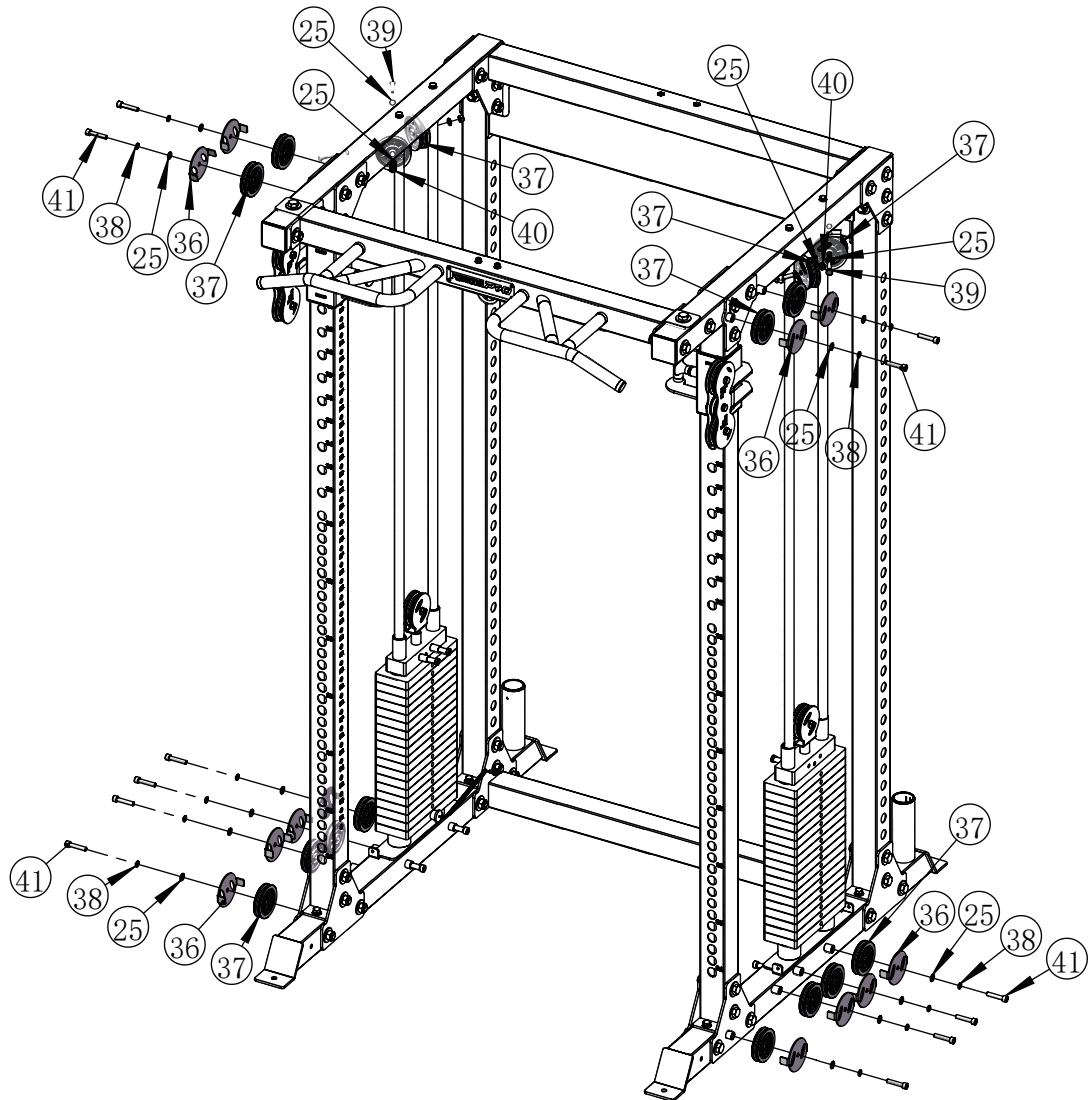

Key No.	Description	Note	Quantity
25	Flat Washer	φ10	20
36	Pulley Cover	T3	12
37	Pulley (96mm)	φ92	16
38	Spring Washer	φ10	12
39	Hexagon Bolt	M10×45	4
40	Lock Nut	M10	4
41	Hexagon Socket Button Head Screw	M10×50	12

# ASSEMBLY STEP 13

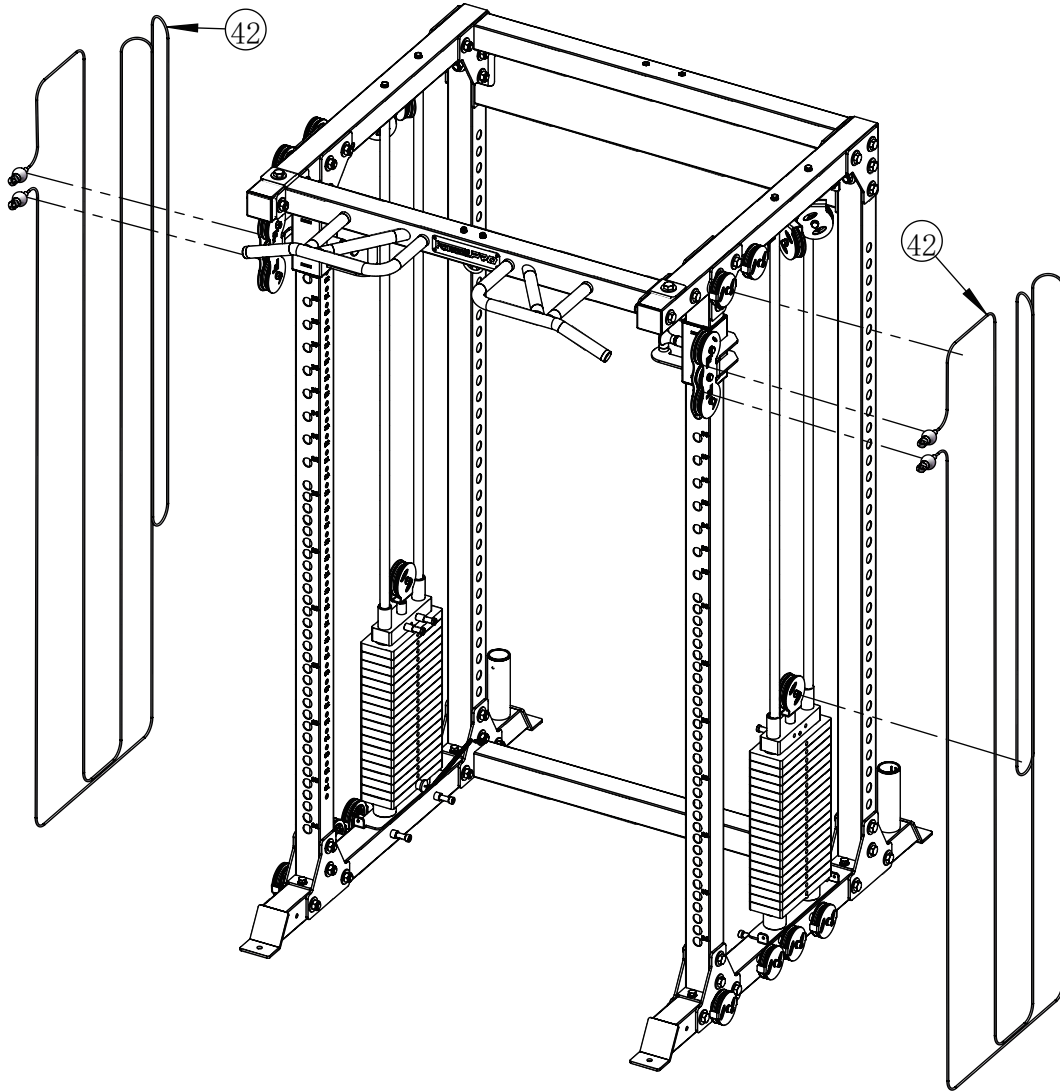

Key No.	Description	Note	Quantity
42	Weight Stack Cable		2

# ASSEMBLY DRAWING

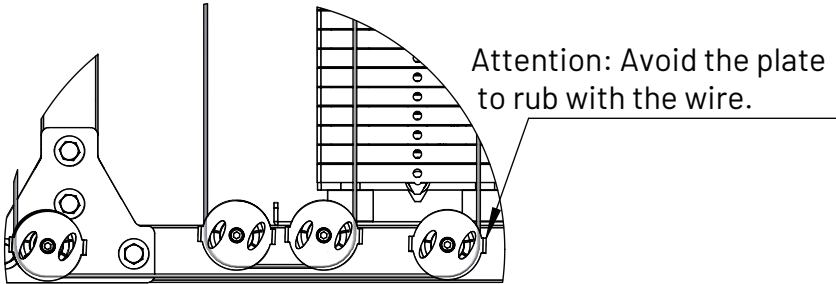
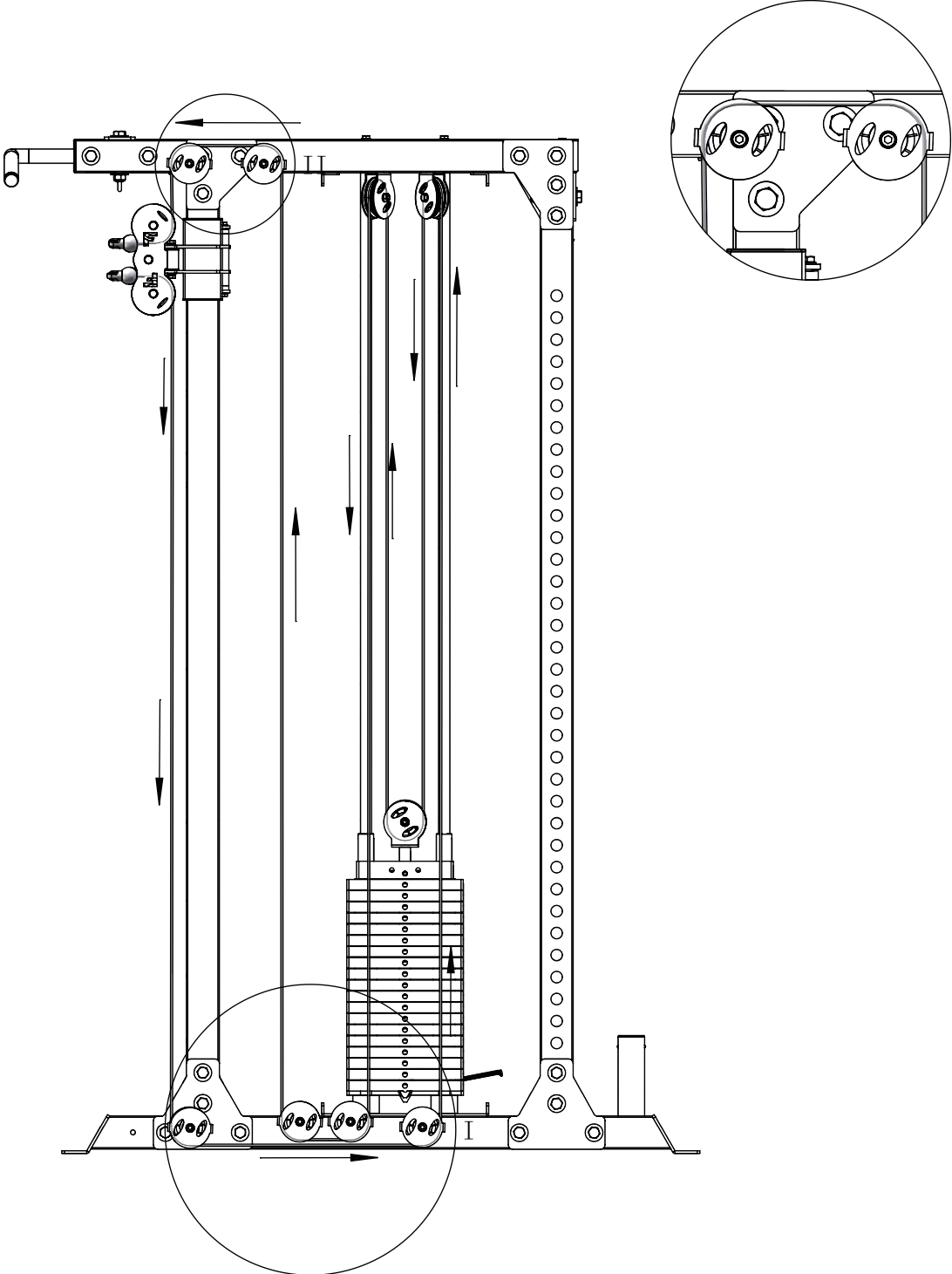

# ASSEMBLY STEP 14

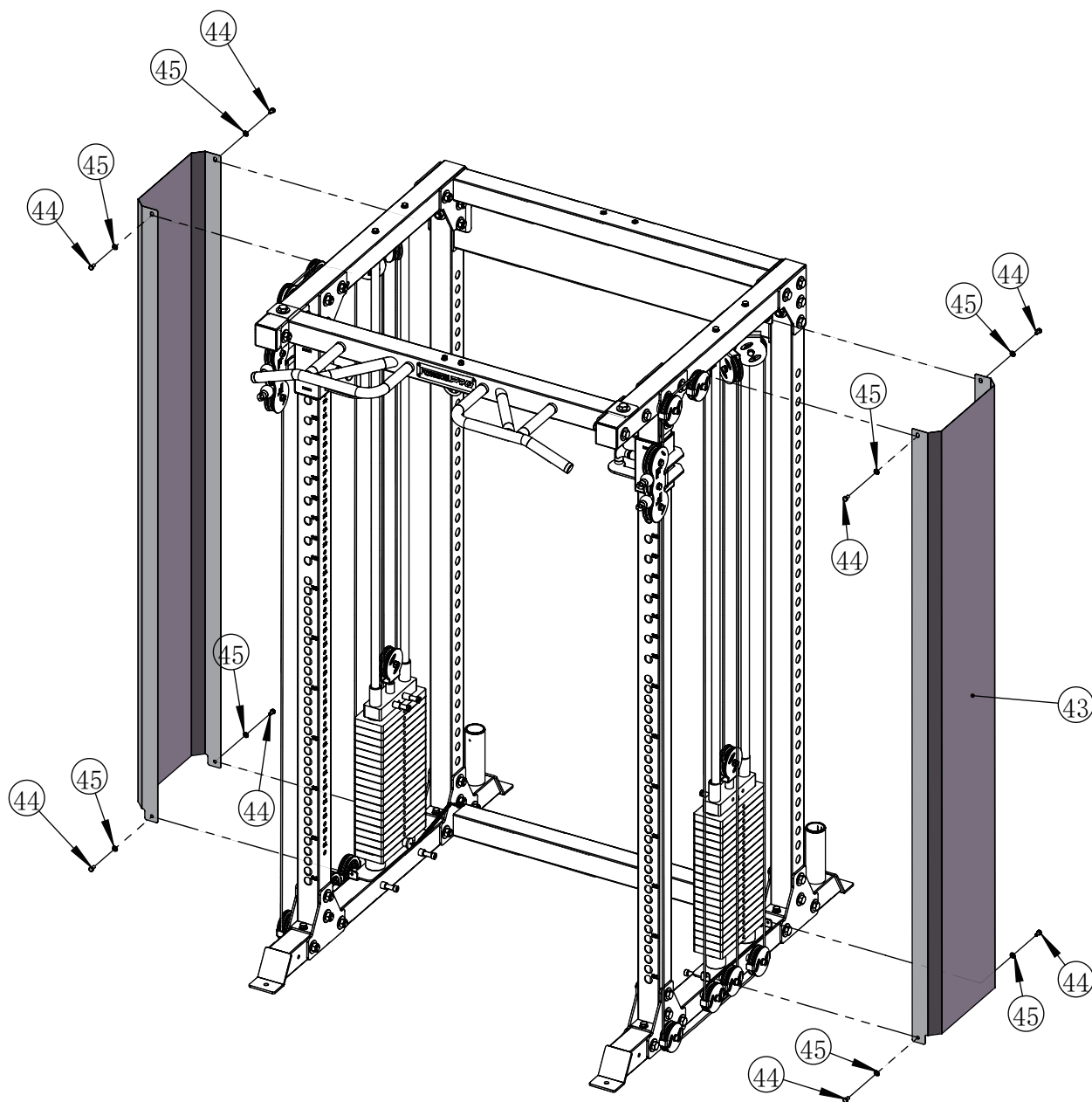

Key No.	Description	Note	Quantity
43	External Weight Stack Shield	T1	2
44	Hexagon Bolt	M8×16	8
45	Flat Washer	φ8	8

# ASSEMBLY STEP 15

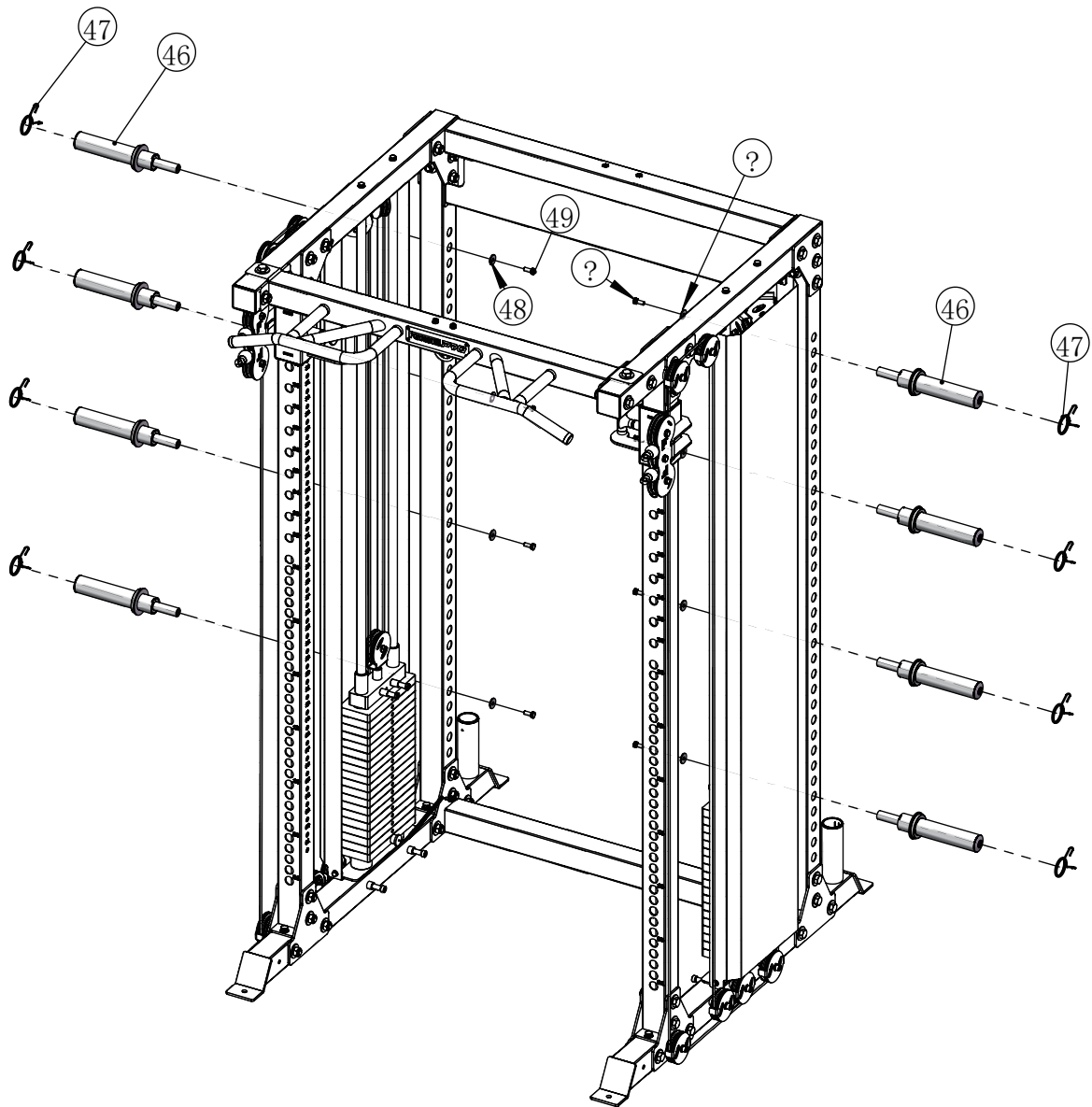

Key No.	Description	Note	Quantity
46	Plate Storage Horn	Assembly Part	8
47	Spring Collars	φ50	8
48	Big Flat Washer	φ30*φ10*3	8
49	Hexagon Bolt	M10×25	8

# ASSEMBLY STEP 16

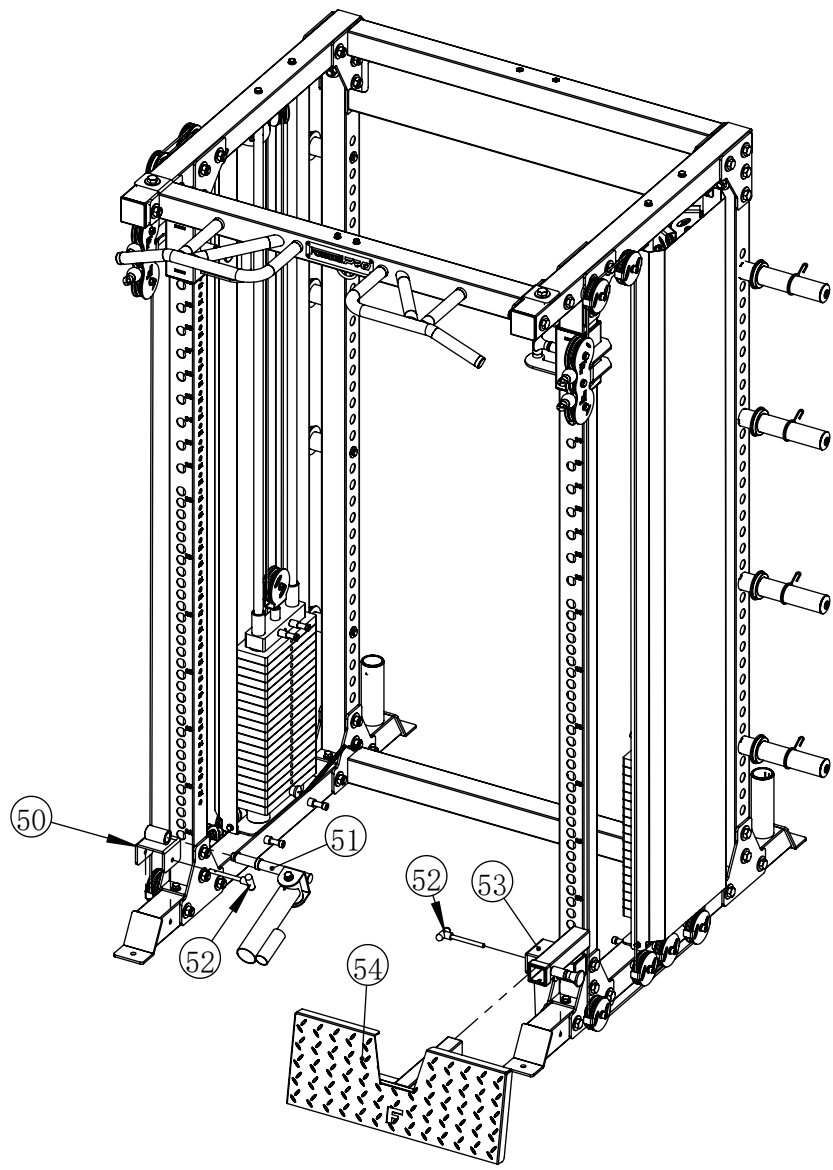

Key No.	Description	Note	Quantity
50	Core Trainer Bracket		1
51	Core Trainer		1
52	T-Shaped Pin	$\phi 10 \times 100$	2
53	Low Row Foot Plate Support Frame		1
54	Low Row Foot Plate		1

# ASSEMBLY STEP 17

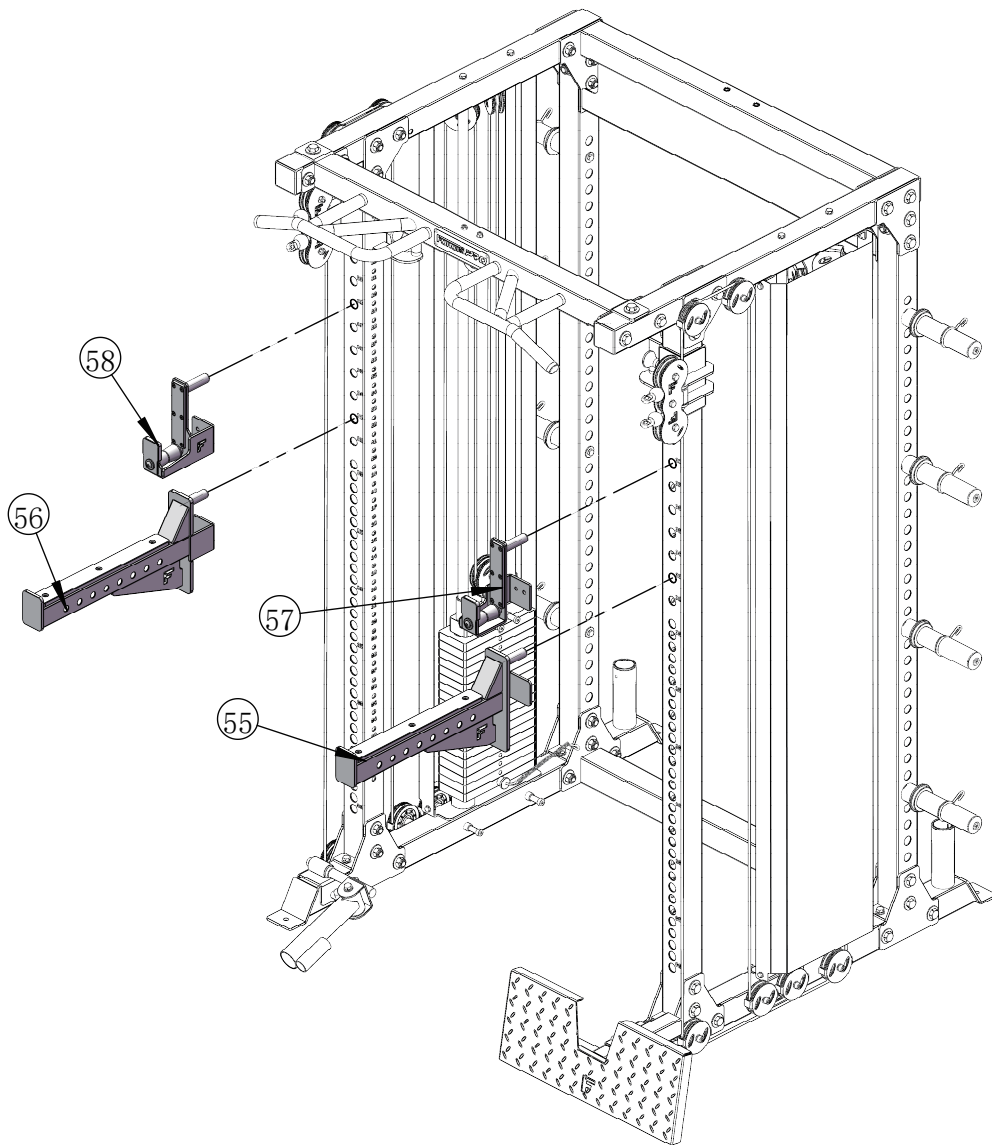

Key No.	Description	Note	Quantity
55	Front Safety - Right		1
56	Front Safety - Left		1
57	J-Hook - Right		1
58	J-Hook - Left		1

# EXPLODED DIAGRAM

1.Base Frame - Left, 1 pc

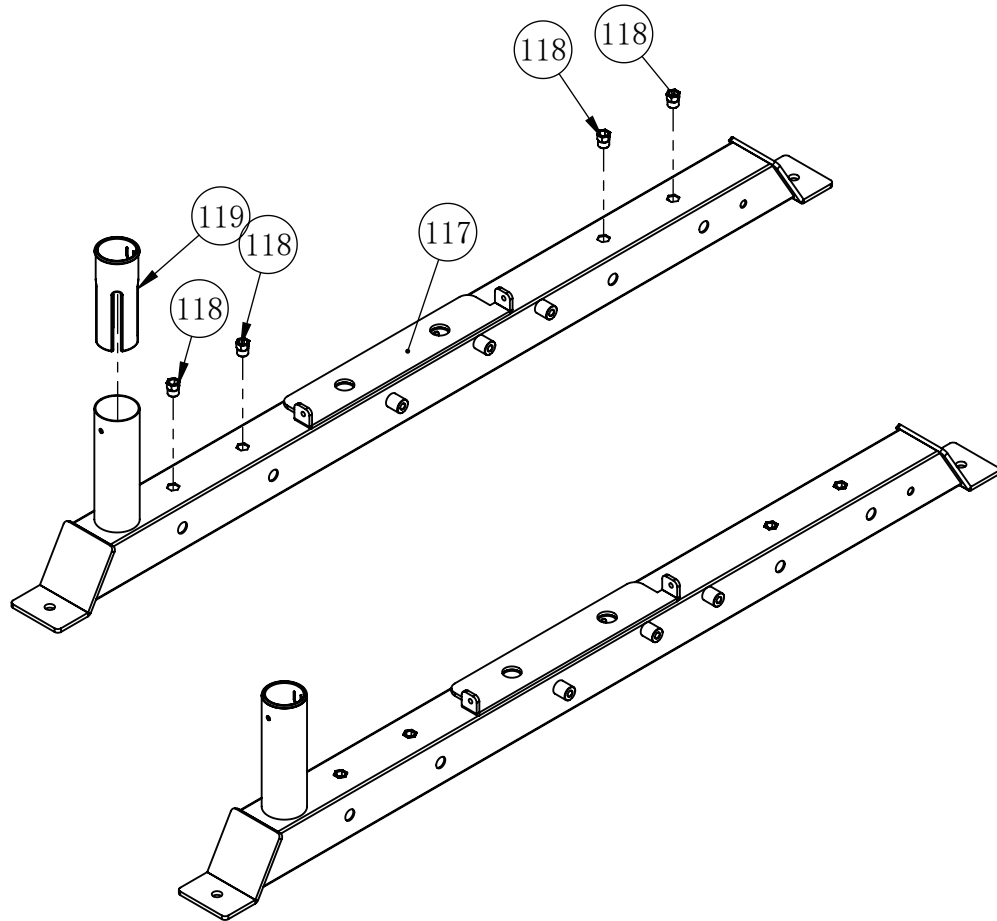

Key No.	Description	Note	Quantity
117	Ground Tube Left		1
118	Countersunk Hexagon Rivet Nut	M12	4
119	Barbell Bar Protection Bushing	$\phi 63 \times 5.8 \times 175$	1



# EXPLODED DIAGRAM

6.Base Frame - Right, 1 pc

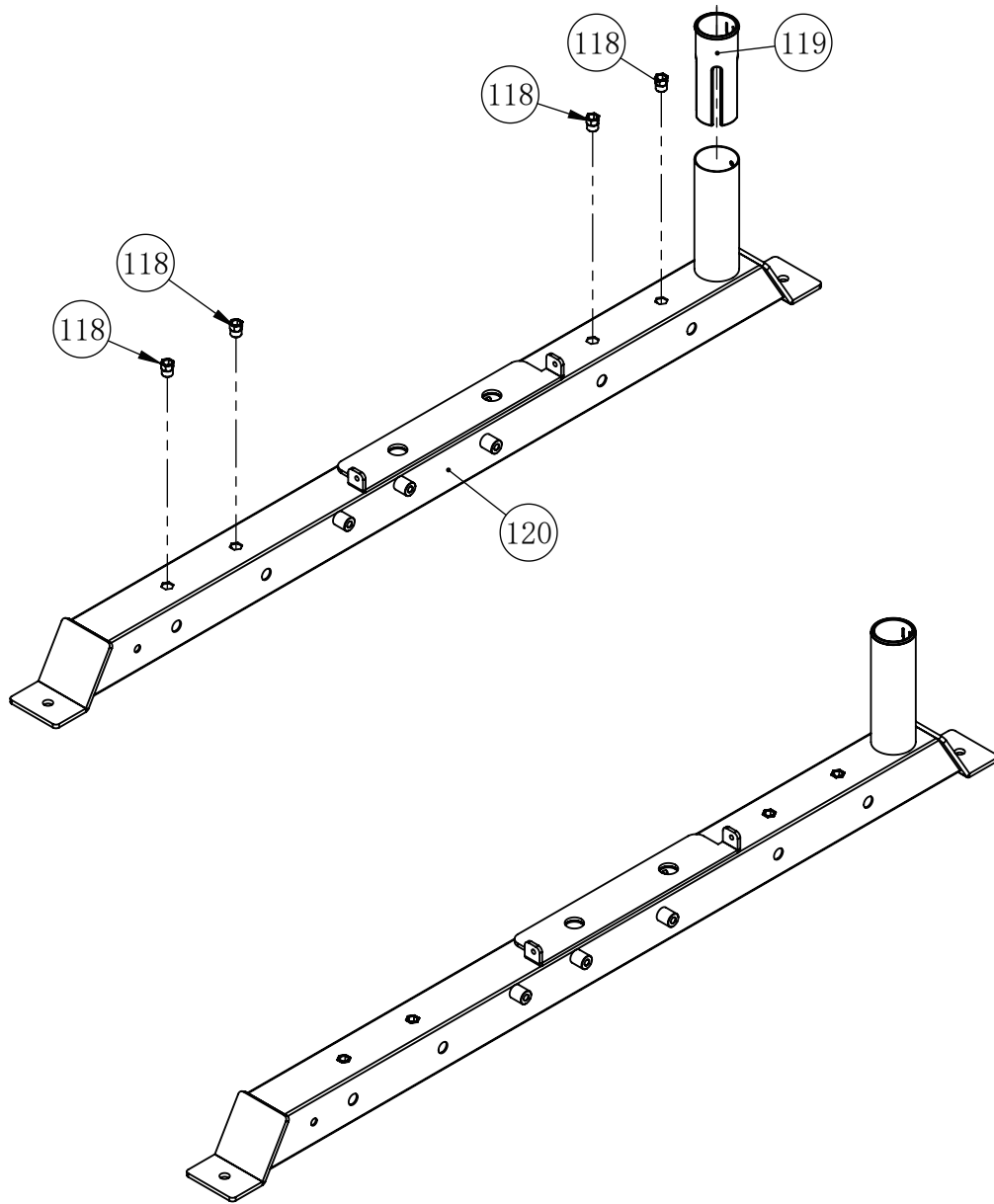

Key No.	Description	Note	Quantity
119	Barbell Bar Protection Bushing	$\phi 63 \times 5.8 \times 175$	1
120	Ground Tube Right		1
118	Countersunk Hexagon Rivet Nut	M12	4

# EXPLODED DIAGRAM

16. Pulley Slider - Left, 1 pc

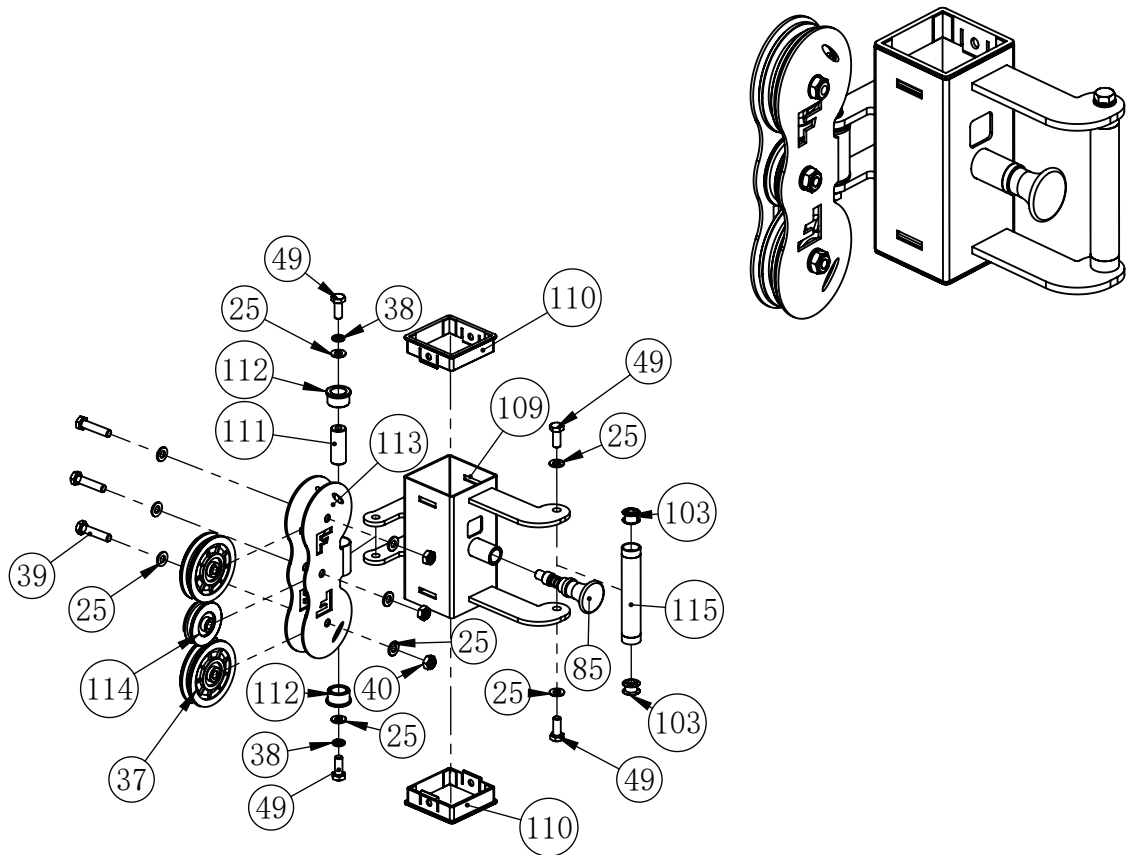

Key No.	Description	Note	Quantity
25	Flat Washer	φ10	10
37	Pulley (96mm)	φ92	2
38	Spring Washer	φ10	2
39	Hexagon Bolt	M10×45	3
40	Lock Nut	M10	3
49	Hexagon Bolt	M10×25	4
85	Umbrella Pin	φ12×M20×40	1
103	Two Layer Spring Nut	φ23-M10	2
109	Sliding Sleeve Left	Welding Part	1
110	Bushing	75-89	2
111	Internal Thread Shaft	Φ19.8*50	1
112	Powder Sleeve	φ33×φ29×φ20×18	2
113	Three Pulley Weldment		1
114	Pulley	φ60	1
115	Handgrip Tube	φ25×2×138	1

# EXPLODED DIAGRAM

17.Pulley Slider - Right, 1 pc

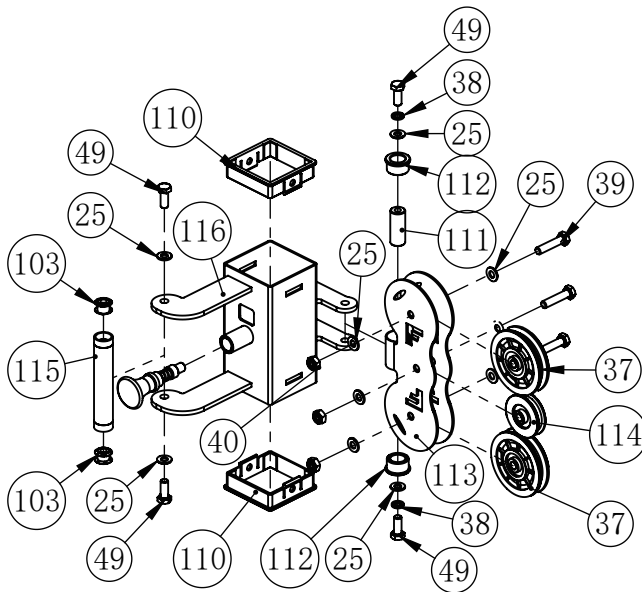
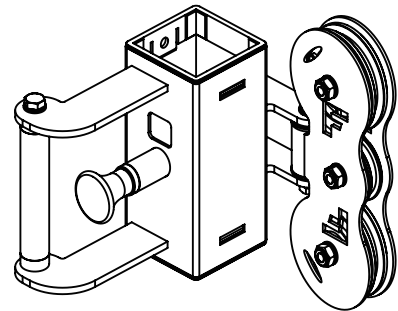

Key No.	Description	Note	Quantity
25	Flat Washer	φ10	10
37	Pulley (96mm)	φ92	2
38	Spring Washer	φ10	2
39	Hexagon Bolt	M10×45	3
40	Lock Nut	M10	3
49	Hexagon Bolt	M10×25	4
85	Umbrella Pin	φ12×M20×40	1
103	Two Layer Spring Nut	φ23-M10	2
110	Bushing	75-89	2
111	Internal Thread Shaft	Φ19.8*50	1
112	Powder Sleeve	φ33×φ29×φ20×18	2
113	Three Pulley Weldment		1
114	Pulley	φ60	1
115	Handgrip Tube	φ25×2×138	1
116	Sliding Sleeve Right		1

# EXPLODED DIAGRAM

18.Weight Stack Guide Rod, 4 pcs

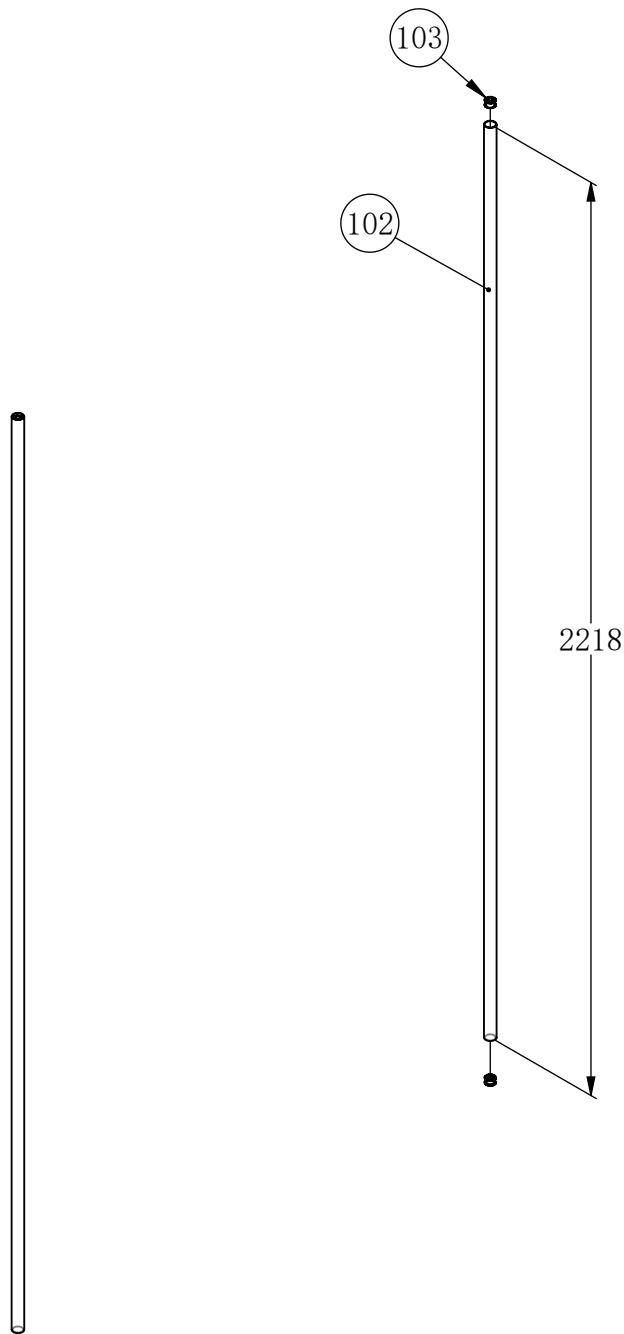

Key No.	Description	Note	Quantity
102	Guide Rod	$\phi 25 \times 1.5$	1
103	Two Layer Spring Nut	$\phi 23 - M10$	2

# EXPLODED DIAGRAM

19.Weight Stack (Includes Top Weight Plate), 2 pcs

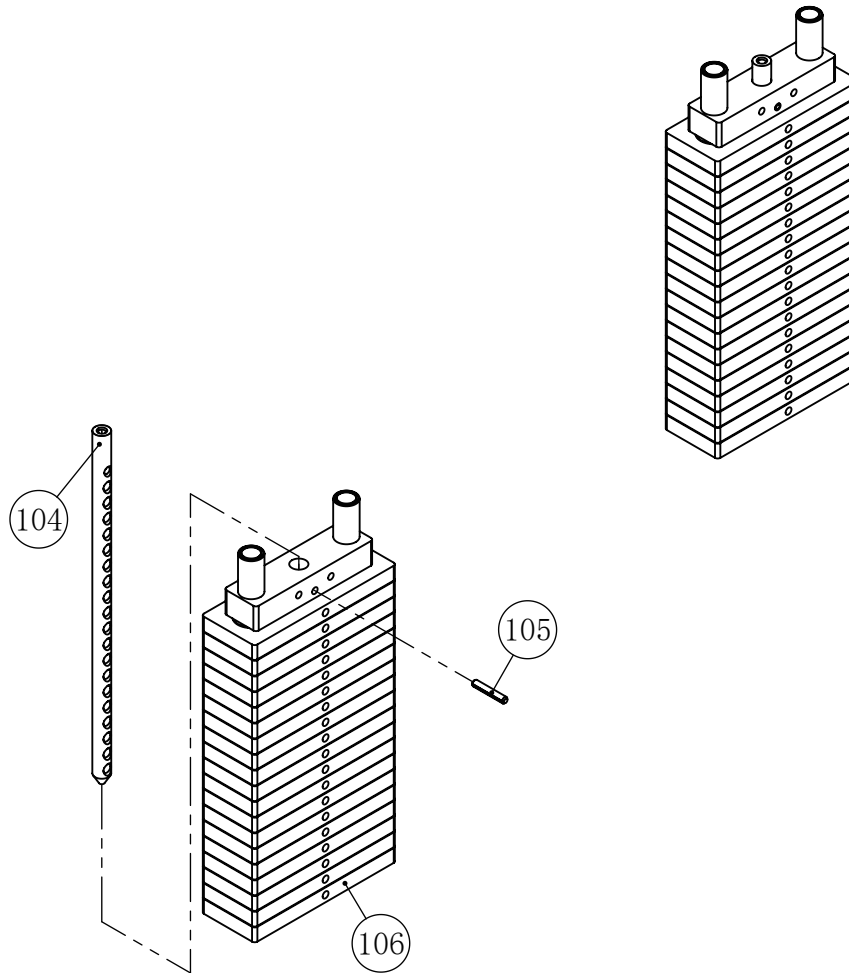

Key No.	Description	Note	Quantity
104	Selector Rod	φ25	1
105	Weight Pin	10×60	1
106	Weight	19+1(90KG)	1

# EXPLODED DIAGRAM

20.Weight Stack Pulley Frame, 2 pcs

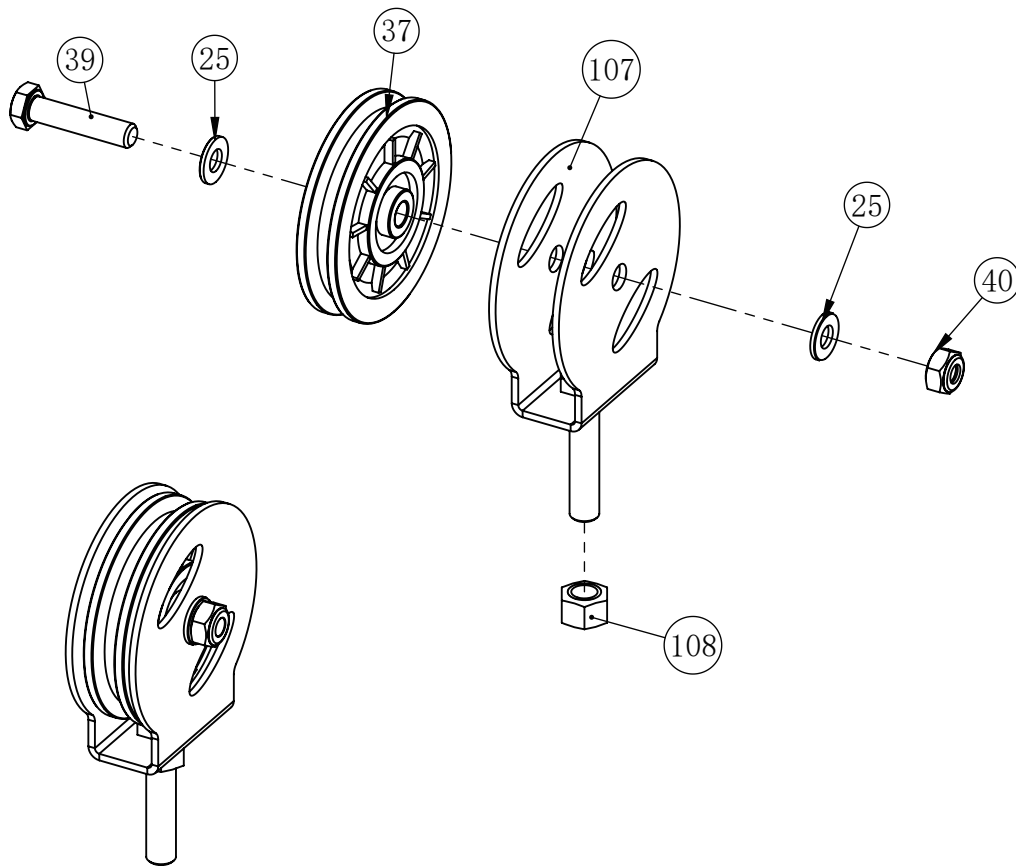

Key No.	Description	Note	Quantity
25	Flat Washer	φ10	2
37	Pulley (96mm)	φ92	1
39	Hexagon Bolt	M10×45	1
40	Lock Nut	M10	1
107	Weight Pulley Bracket		1
108	Hexagon Nut	M12	1

# EXPLODED DIAGRAM

29.Upper Frame - Left, 1 pc

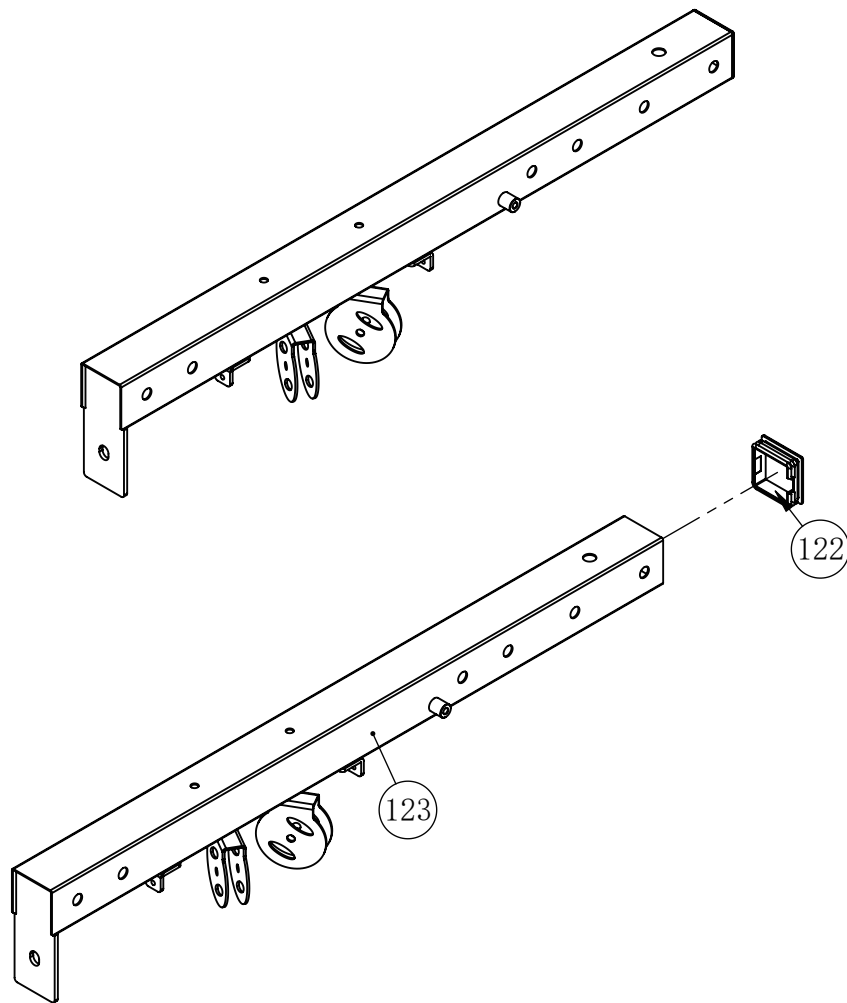

Key No.	Description	Note	Quantity
122	Square Tube Inner Plug	□75×75×2.5	1
123	Upper Beam Left Weldment		1

# EXPLODED DIAGRAM

30. Logo Board , 1 pc

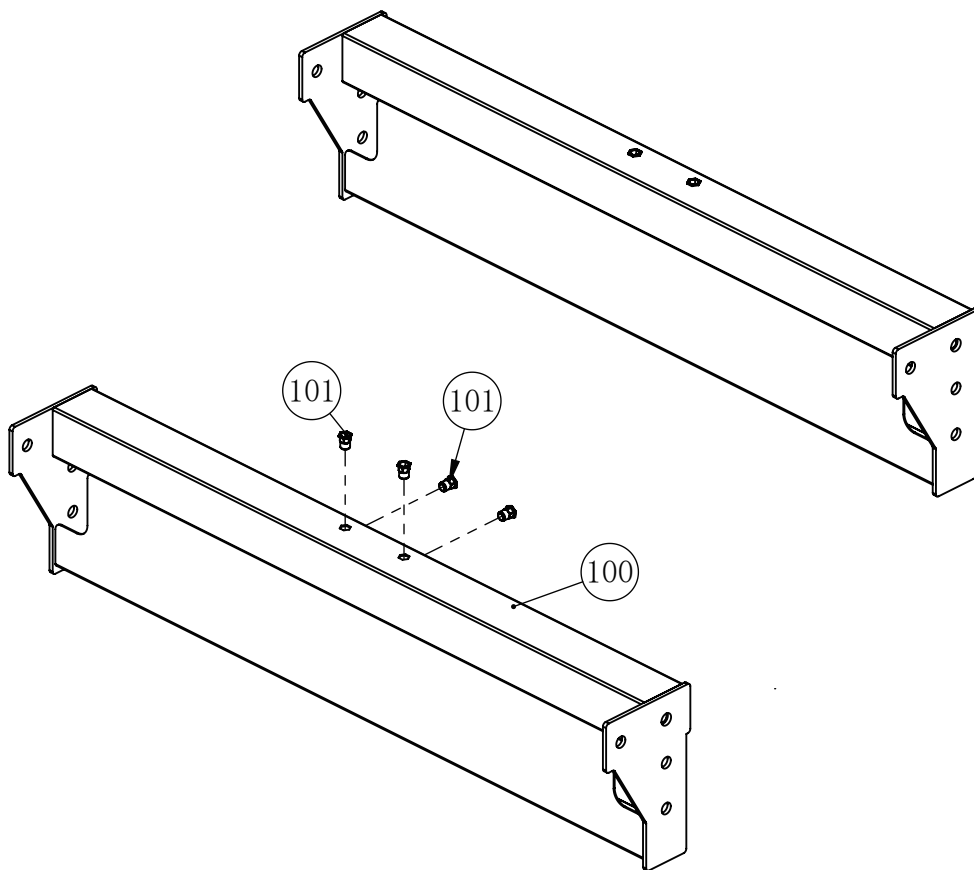

Key No.	Description	Note	Quantity
100	Rear Upper Beam		1
101	Countersunk Hexagon Rivet Nut	M10	4



# EXPLODED DIAGRAM

35.Chin Up Frame, 1 pc

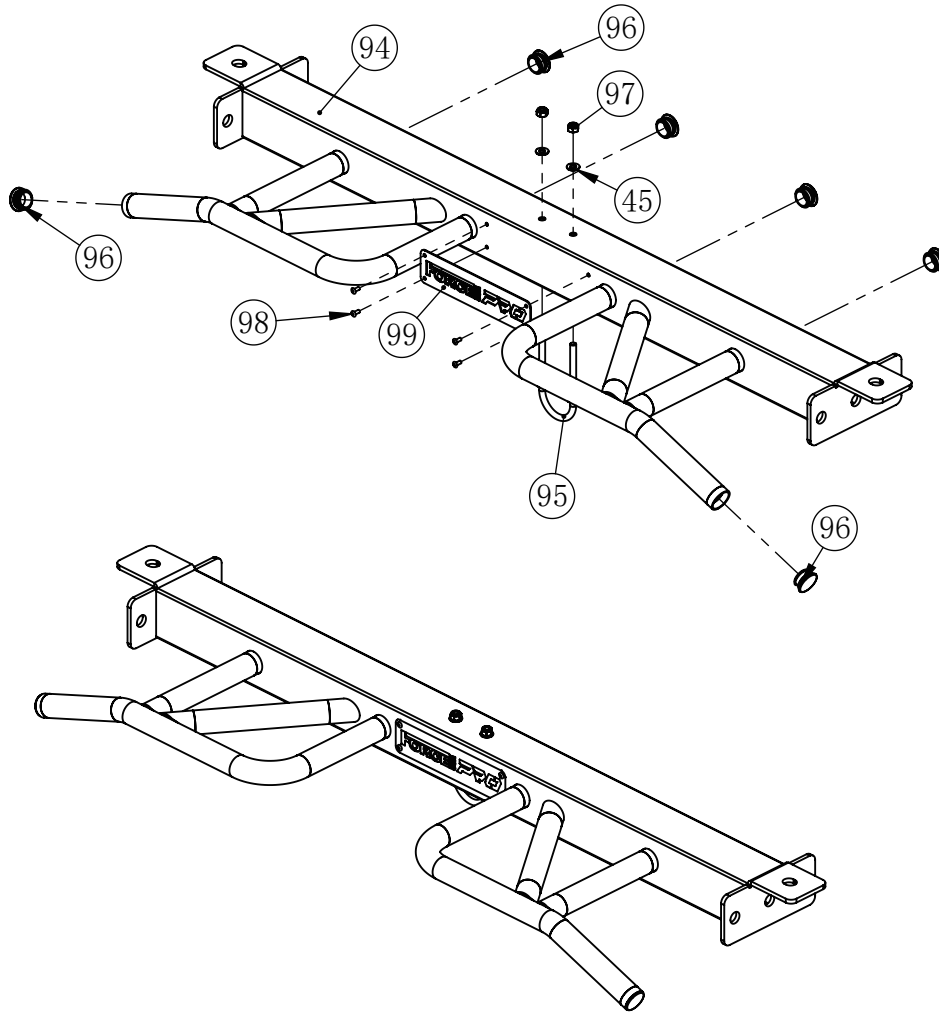

Key No.	Description	Note	Quantity
45	Flat Washer	φ8	2
94	Front Upper Beam		1
95	Face Hanging Ring		1
96	Round Tube Plug	φ32×1.5	6
97	Lock Nut	M8	2
98	Oval Round No Core Rivet	4×10	4
99	Scutcheon	T1.5	1

# EXPLODED DIAGRAM

46. Plate Storage Horn, 8 pcs

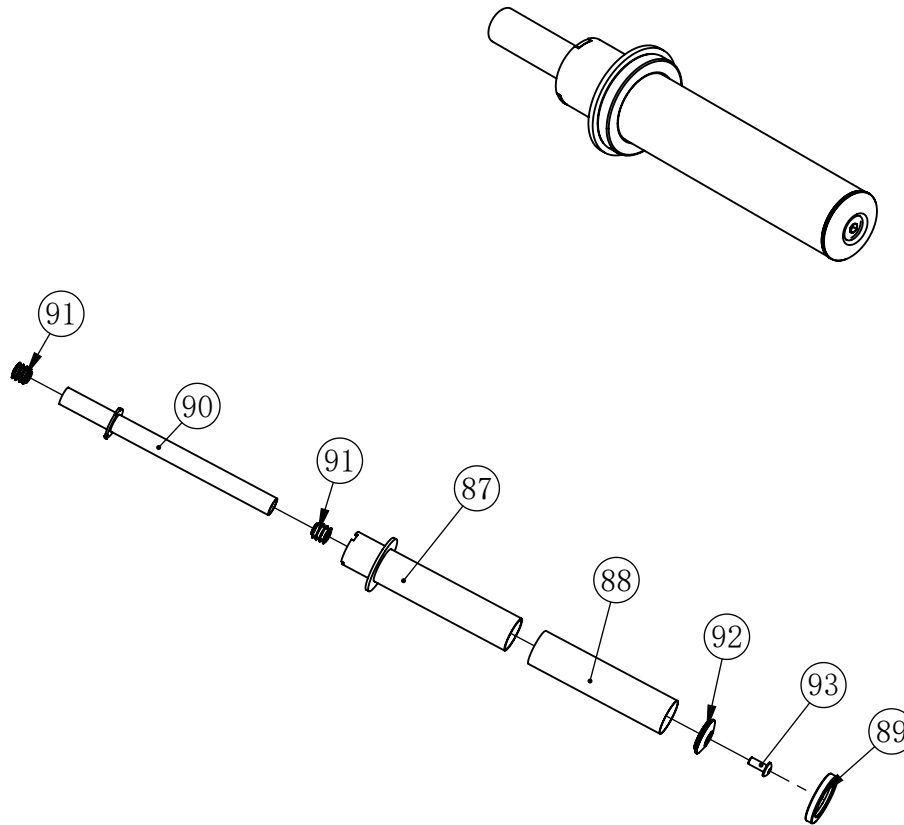

Key No.	Description	Note	Quantity
87	Barbell Plate Holder		1
88	Outer Sleeve Tube	$\phi 49.5 \times 0.6 \times 200$	1
89	Rubber Stop Collar	$\phi 70 \times \phi 50 \times \phi 10$	1
90	Barbell Bar Holder Inner Rod		1
91	Four Layer Spring Screw	$\phi 23 - M10$	2
92	Decorative Cover	$\phi 11 \times \phi 18 \times \phi 42 \times \phi 50$	1
93	Hexagon Socket Button Head Screw	M10×25	1

# EXPLODED DIAGRAM

51.Core Trainer, 1 pc

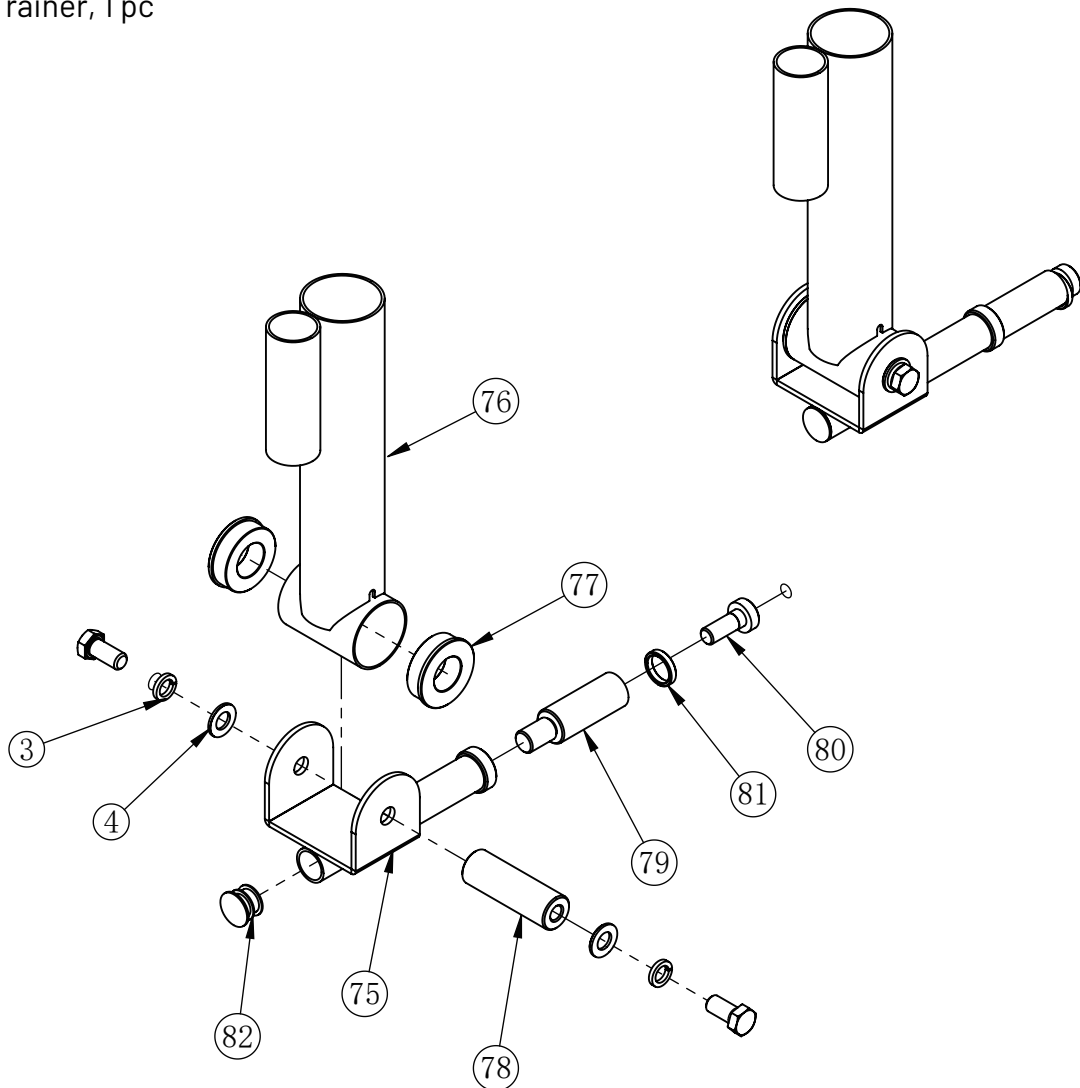

Key No.	Description	Note	Quantity
3	Hexagon Bolt	M12×25	2
4	Flat Washer	φ12	2
5	Spring Washer	φ12	2
75	Core Trainer New Weldment		1
76	Double Barbell Core Trainer		1
77	Powder Sleeve	φ50×φ47×φ25×15	2
78	Internal Thread Shaft	φ25*77*M12	1
79	Barbell Bar Plug	φ25*86	1
80	Barbell Bar Limit Shaft	φ22*39.5	1
81	Limit Ring	φ25*φ20*5	1
82	Round Tube Inner Plug	Φ25×2	1

# EXPLODED DIAGRAM

53.Low Row Foot Plate Support Frame, 1 pc

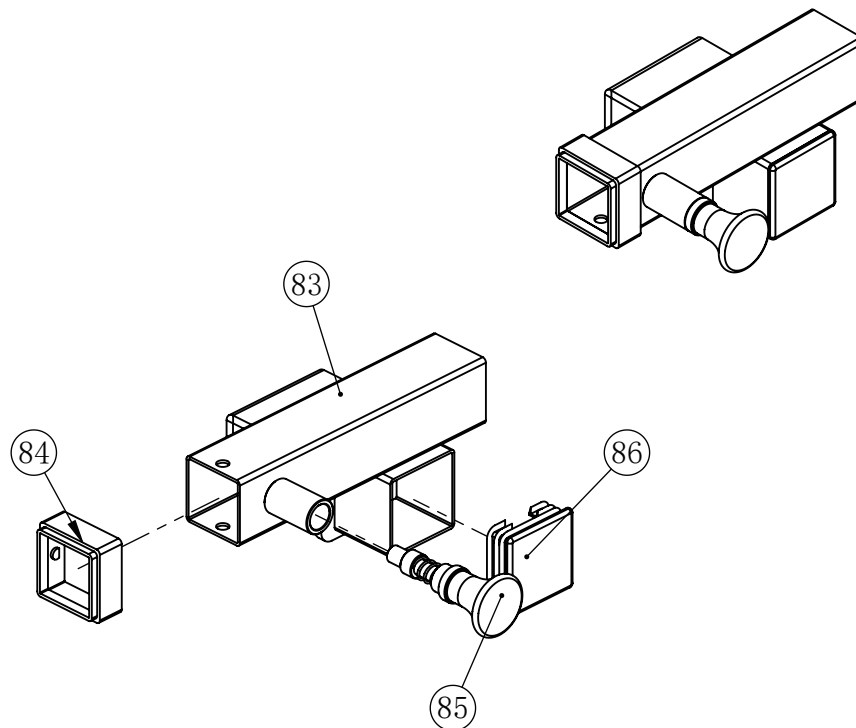

Key No.	Description	Note	Quantity
83	Foot Plate Bracket Weldment		1
84	Reducer Sleeve	□50×50/45×45	1
85	Umbrella Pin	φ12×M20×40	1
86	Square Tube Inner Plug	□60×60×2	1

# EXPLODED DIAGRAM

55.Front Safety - Right, 1 pc

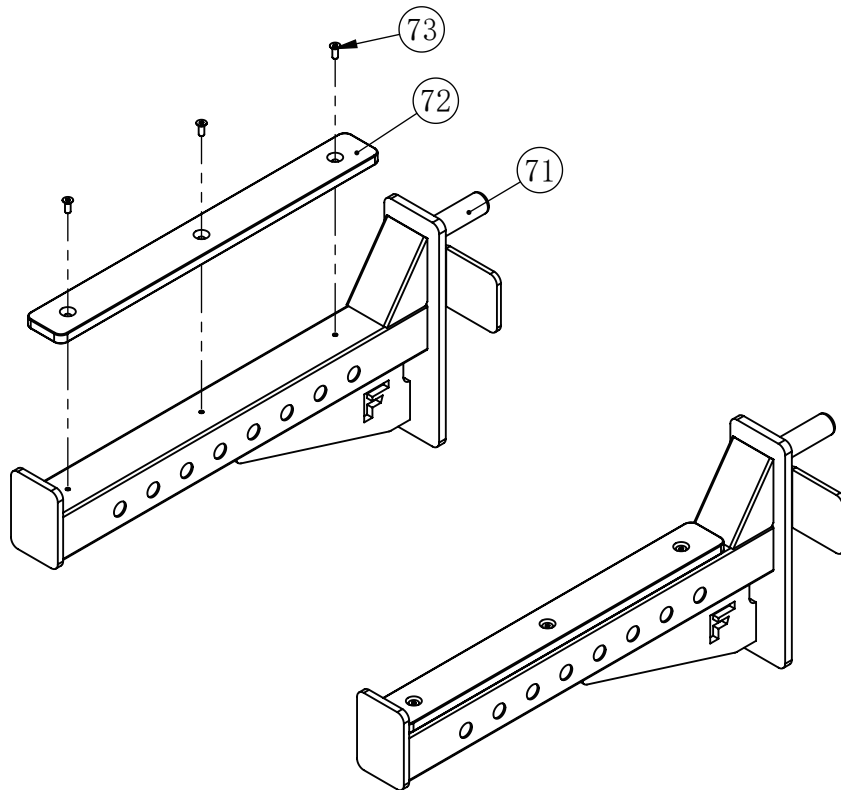

Key No.	Description	Note	Quantity
71	Safety Spotter Weldment Right		1
72	Safety Spotter Rubber Sheet	T12	1
73	Countersunk Hexagon Screw	M6×16	3

# EXPLODED DIAGRAM

56.Front Safety - Left, 1 pc

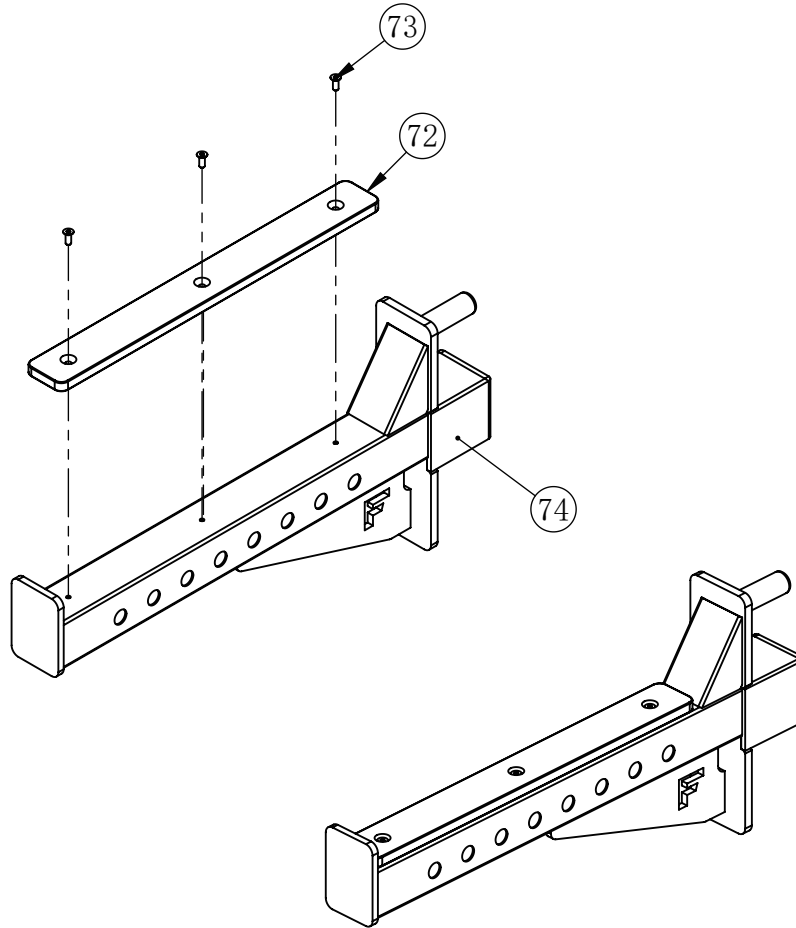

Key No.	Description	Note	Quantity
72	Safety Spotter Rubber Sheet	T12	1
73	Countersunk Hexagon Screw	M6×16	3
74	Safety Spotter Weldment Left		1

# EXPLODED DIAGRAM

57.J-Hook - Right, 1 pc

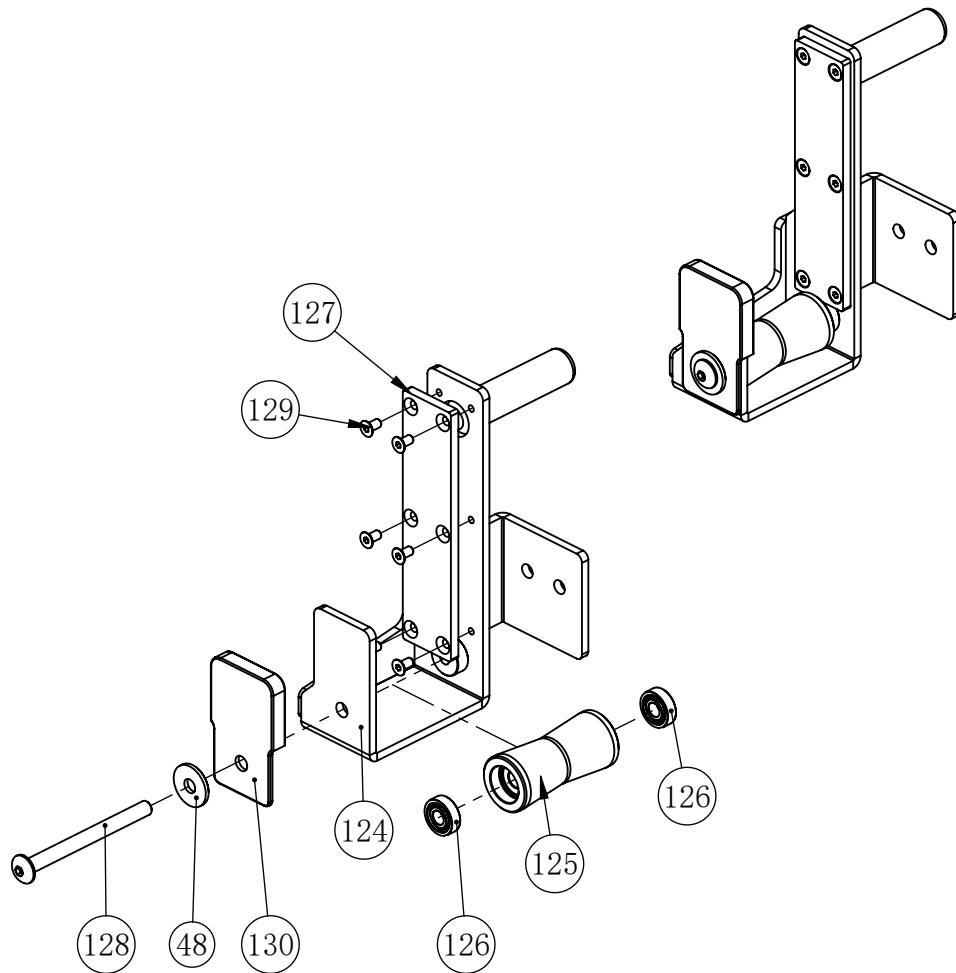

Key No.	Description	Note	Quantity
48	Big Flat Washer	$\phi 30 \times \phi 10 \times 3$	1
124	J Hook Right Weldment		1
125	J Hook Roller	$\phi 40 \times 88$	1
126	Deep Groove Ball Bearing	6000	2
127	Rubber Sheet	$\phi 190 \times 45 \times 7$	1
128	Hexagon Socket Button Head Screw	M10 $\times$ 115	1
129	Countersunk Hexagon Screw	M6 $\times$ 12	6
130	J Hook Front Rubber Sheet	12.3 $\times$ 96	1

# EXPLODED DIAGRAM

58.J-Hook - Left, 1 pc

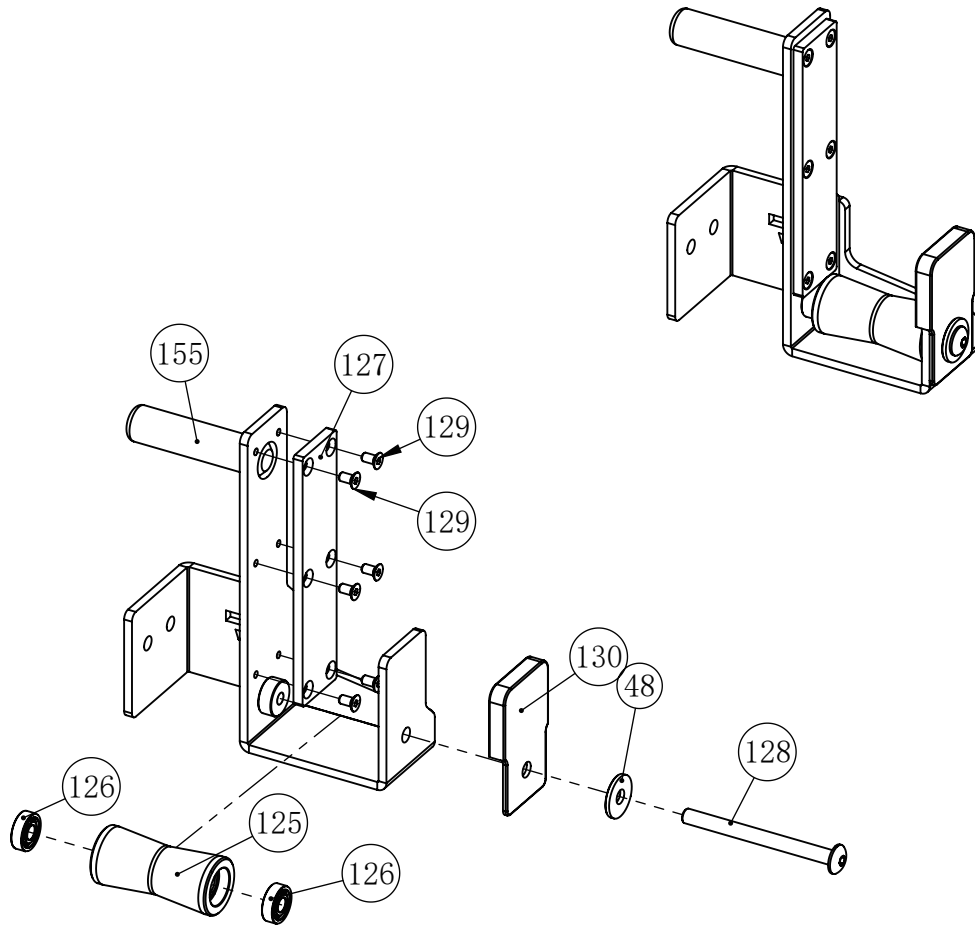

Key No.	Description	Note	Quantity
48	Big Flat Washer	$\phi 30 * \phi 10 * 3$	1
125	J Hook Roller	$\phi 40 * 88$	1
126	Deep Groove Ball Bearing	6000	2
127	Rubber Sheet	$\phi 190 * 45 * 7$	1
128	Hexagon Socket Button Head Screw	M10×115	1
129	Countersunk Hexagon Screw	M6×12	6
130	J Hook Front Rubber Sheet	12.3*96	1
155	J-hook Left		1



# EXPLODED DIAGRAM

66.Connection Bar -Straight, 1 pc

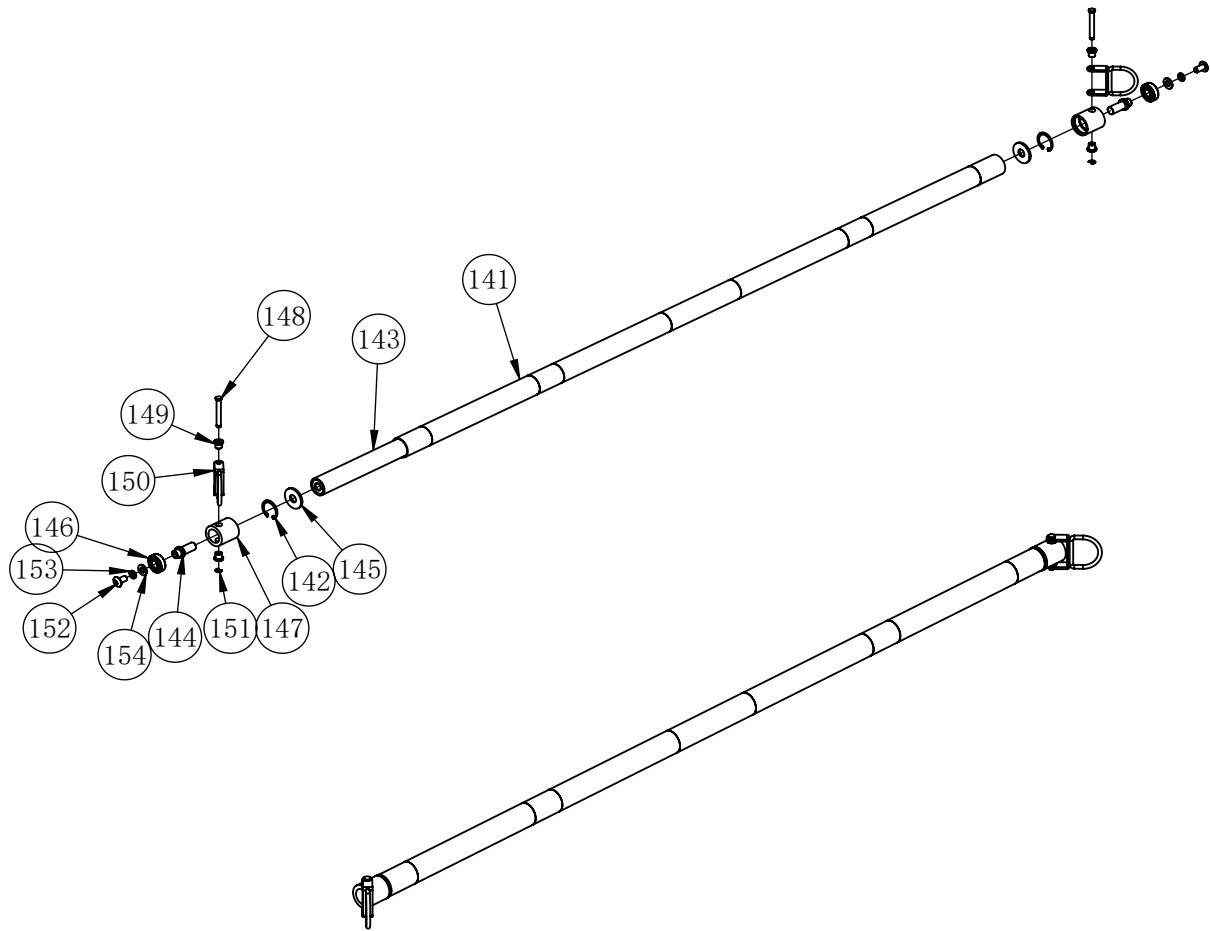

Key No.	Description	Note	Quantity
141	Straight Bar 1222	Aluminium Alloy	1
142	Spring Stop Collar A	28	2
143	Screw	Welding Part	1
144	Internal Thread Shaft	$\phi 17 \times 38$	2
145	Gasket	$\phi 33 \times \phi 12.5 \times T3$	2
146	Deep Groove Ball Bearing	6001-2RS	2
147	Bearing Sleeve	$\phi 33 \times \phi 22$	2
148	T-shaped Cotter Pin	$\phi 9.4 \times \phi 6.3$	2
149	Cotter Pin Bushing	$\phi 13 \times \phi 9.45$	4
150	U-shaped Fastener		2
151	Stop Collar	5	2
152	Hexagon Socket Button Head Screw	M8 $\times$ 16	2
153	Spring Gasket	$\phi 8$	2
154	Flat Gasket	$\phi 8$	2

# EXPLODED DIAGRAM

121.Upper Beam Right Weldment, 1pc

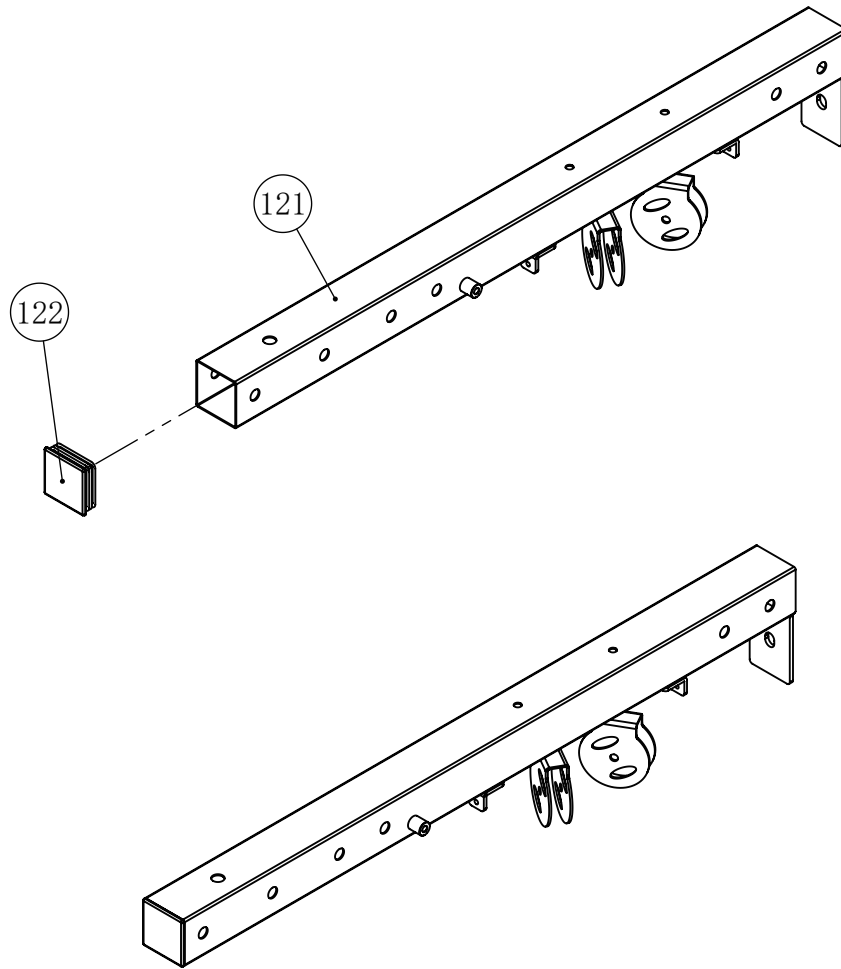

Key No.	Description	Note	Quantity
121	Upper Beam Right Weldment		1
122	Square Tube Inner Plug	□75×75×2.5	1

# PARTS LIST

Key No.	Description	Note	Quantity
1	Base Frame - Left		1
2	Rear Upright		2
3	Hexagon Bolt	M12×25	10
4	Flat Washer	φ12	10
5	Spring Washer	φ12	10
6	Base Frame - Right		1
7	Rear Base Frame		1
8	Rear Base Fixing Plate	T6	4
9	Hexagon Bolt	M16×110	30
10	Flat Washer	φ17×φ40×3	74
11	Lock Nut	M16	36
12	Front Upright - Left (silver)		1
13	Front Upright - Right (silver)		1
14	Front External Base Fixing Plate - Left		1
15	Front External Base Fixing Plate - Right		1
16	Pulley Slider - Left		1
17	Pulley Slider - Right		1
18	Weight Stack Guide Rod		4
19	Weight Stack (Includes Top Weight Plate)		2
20	Weight Stack Pulley Frame	φ60×φ27×42	2
21	Rubber Bumper - Weight Stack	φ10×100	4
22	Weight Stack Selector Pin	φ17.8×17-M12	2
23	Weight Stack Locking Shaft	13×30-M10	4
24	Internal Hex Column Screw	φ10	4
25	Flat Washer	M10×95	48
26	Hexagon Bolt		4
27	Upper Frame - Right	M16×105	1
28	Hexagon Bolt		8
29	Upper Frame - Left		1
30	Logo Board	T6	1
31	Rear External Top Fixing Plate		2
32	Front External Top Fixing Plate - Left	T6	1
33	Front Internal Top Fixing Plate		2
34	Front External Top Fixing Plate - Right		1
35	Chin Up Frame	T3	1
36	Pulley Cover	φ92	12
37	Pulley (96mm)	φ10	22
38	Spring Washer	M10×45	18
39	Hexagon Bolt		12

## PARTS LIST

Key No.	Description	Note	Quantity
40	Lock Nut	M10	12
41	Hexagon Socket Button Head Screw	M10×50	12
42	Weight Stack Cable		2
43	External Weight Stack Shield	T1	2
44	Hexagon Bolt	M8×16	8
45	Flat Washer	φ8	10
46	Plate Storage Horn		8
47	Spring Collars	φ50	8
48	Big Flat Washer	φ30*φ10*3	10
49	Hexagon Bolt	M10×25	16
50	Core Trainer Bracket		1
51	Core Trainer		1
52	T-shaped Pin	φ10×100	2
53	Low Row Foot Plate Support Frame		1
54	Low Row Foot Plate		1
55	Front Safety - Right		1
56	Front Safety - Left		1
57	J-Hook - Right		1
58	J-Hook - Left		1
59	J-Hook Flat Shock Pad		2
60	Horizontal Bar		1
61	Single Stirrup - Nylon		2
62	Extension Chain	φ6	2
63	Carabiner		11
64	V-bar		1
65	Lat Pull Down Bar		1
66	Connection Bar -Straight		1
67	Tricep Rope	φ28*690	1
68	Short Straight Bar		1
69	Ankle Cuff	Leather with Ring	1
70	Close Grip Triangle		1
71	Safety Spotter Weldment Right		1
72	Safety Spotter Rubber Sheet	T12	2
73	Countersunk Hexagon Screw	M6×16	6
74	Safety Spotter Weldment Left		1
75	Core Trainer New Weldment		1
76	Double Barbell Core Trainer		1
77	Powder Sleeve	φ50×φ47×φ25×15	2
78	Internal Thread Shaft	φ25*77*M12	1
79	Barbell Bar Plug	φ25*86	1

# PARTS LIST

Key No.	Description	Note	Quantity
80	Barbell Bar Limit Shaft	φ22*39.5	1
81	Limit Ring	φ25*φ20*5	1
82	Round Tube Inner Plug	Φ25×2	1
83	Foot Plate Bracket Weldment	Welding Part	1
84	Reducer Sleeve	□50×50/45×45	1
85	Umbrella Pin	φ12×M20×40	3
86	Square Tube Inner Plug	□60×60×2	1
87	Barbell Plate Holder	Welding Part	8
88	Outer Sleeve Tube	φ49.5*0.6*200	8
89	Rubber Stop Collar	φ70×φ50×φ10	8
90	Barbell Bar Holder Inner Rod	Welding Part	8
91	Four Layer Spring Screw	φ23-M10	16
92	Decorative Cover	φ11×φ18×φ42×φ50	8
93	Hexagon Socket Button Head Screw	M10×25	1
94	Front Upper Beam	Welding Part	1
95	Face Hanging Ring	Welding Part	1
96	Round Tube Plug	φ32×1.5	6
97	Lock Nut	M8	2
98	Oval Round No Core Rivet	4×10	4
99	Scutcheon	T1.5	1
100	Rear Upper Beam	Welding Part	1
101	Countersunk Hexagon Rivet Nut	M10	4
102	Guide Rod	φ25×1.5	4
103	Two Layer Spring Nut	φ23-M10	12
104	Selector Rod	φ25	2
105	Weight Pin	10×60	2
106	Weight	19+1(90KG)	2
107	Weight Pulley Bracket	Welding Part	2
108	Hexagon Nut	M12	2
109	Sliding Sleeve Left	Welding Part	1
110	Bushing	75-89	4
111	Internal Thread Shaft	Φ19.8*50	2
112	Powder Sleeve	φ33×φ29×φ20×18	4
113	Three Pulley Weldment	Welding Part	2
114	Pulley	φ60	2
115	Handgrip Tube	φ25×2×138	2

# PARTS LIST

Key No.	Description	Note	Quantity
116	Sliding Sleeve Right		1
117	Ground Tube Left		1
118	Countersunk Hexagon Rivet Nut	M12	8
119	Barbell Bar Protection Bushing	φ63*5.8×175	2
120	Ground Tube Right		1
121	Upper Beam Right Weldment		1
122	Square Tube Inner Plug	□75×75×2.5	2
123	Upper Beam Left Weldment		1
124	J Hook Right Weldment		1
125	J Hook Rollar	φ40*88	2
126	Deep Groove Ball Bearing	6000	4
127	Rubber Sheet	φ190×45×7	2
128	Hexagon Socket Button Head Screw	M10×115	2
129	Countersunk Hexagon Screw	M6×12	12
130	J Hook Front Rubber Sheet	12.3*96	2
131	Lat Pull Down Bar Bent Tube	φ25*2	1
132	Handgrip Outer Stop Collar	φ31.5×φ25.5	2
133	Two Layer Spring Nut	φ23-M8	2
134	Lat Pull Down Bar Hanging Plate	T6	1
135	Lat Pull Down Bar Stop Collar	φ39×φ26×12	2
136	Handgrip Internal Stop Collar	φ33×φ26×10.5	2
137	Dip Plastic Handgrip	φ25*480	2
138	Internal Hexagon Sunk Lock Screw	M6*6	6
139	Countersunk Cross Recessed Screw	M8×20	2
140	Grub Screw	M4×3	4
141	Straight Bar 1222	Aluminium Alloy	1
142	Spring Stop Collar A	28	2
143	Screw		1
144	Internal Thread Shaft	φ17*38	2
145	Gasket	φ33*φ12.5*T3	2
146	Deep Groove Ball Bearing	6001-2RS	2
147	Bearing Sleeve	φ33*φ22	2
148	T-shaped Cotter Pin	φ9.4*φ6.3	2
149	Cotter Pin Bushing	φ13*φ9.45	4
150	U-shaped Fastener		2
151	Stop Collar	5	2
152	Hexagon Socket Button Head Screw	M8×16	2
153	Spring Gasket	φ8	2
154	Flat Gasket	φ8	2
155	J-hook Left		1



We believe success comes from striving to be better than yesterday. It comes from the urge to push boundaries and break through barriers. Fueled with the belief that everybody deserves a fit and healthy lifestyle, we are dedicated to providing innovative strength and fitness solutions to build stronger, happier and healthier lives.

## **WARRANTY**

The Force USA range of strength equipment carries a Lifetime (10 Year) Structural Warranty along with two years cover on all moving parts and 90 days warranty on all upholstery items. This warranty applies to first owners and does not cover second-hand equipment or re-sold equipment. This Force USA warranty covers only failures due to defects in structural elements, cables and pulleys and workmanship that occur during regular use in the warranted environment. It will not cover damage that occurs in transport/delivery or failure due to misuse, abuse, neglect, misapplication, alteration or improper assembly of the product. The replacement or repair provided for under the Force USA warranty is the responsibility of the user, and the customer will be responsible for any freight charges that apply. Force USA will not be liable for any consequential damages or breach of any implied warranty on the range of Force USA strength equipment. Force USA reserves the right to provide reconditioned parts and/or to request a return and repair existing defective components on the Force USA product.