

FORCE^{USA}

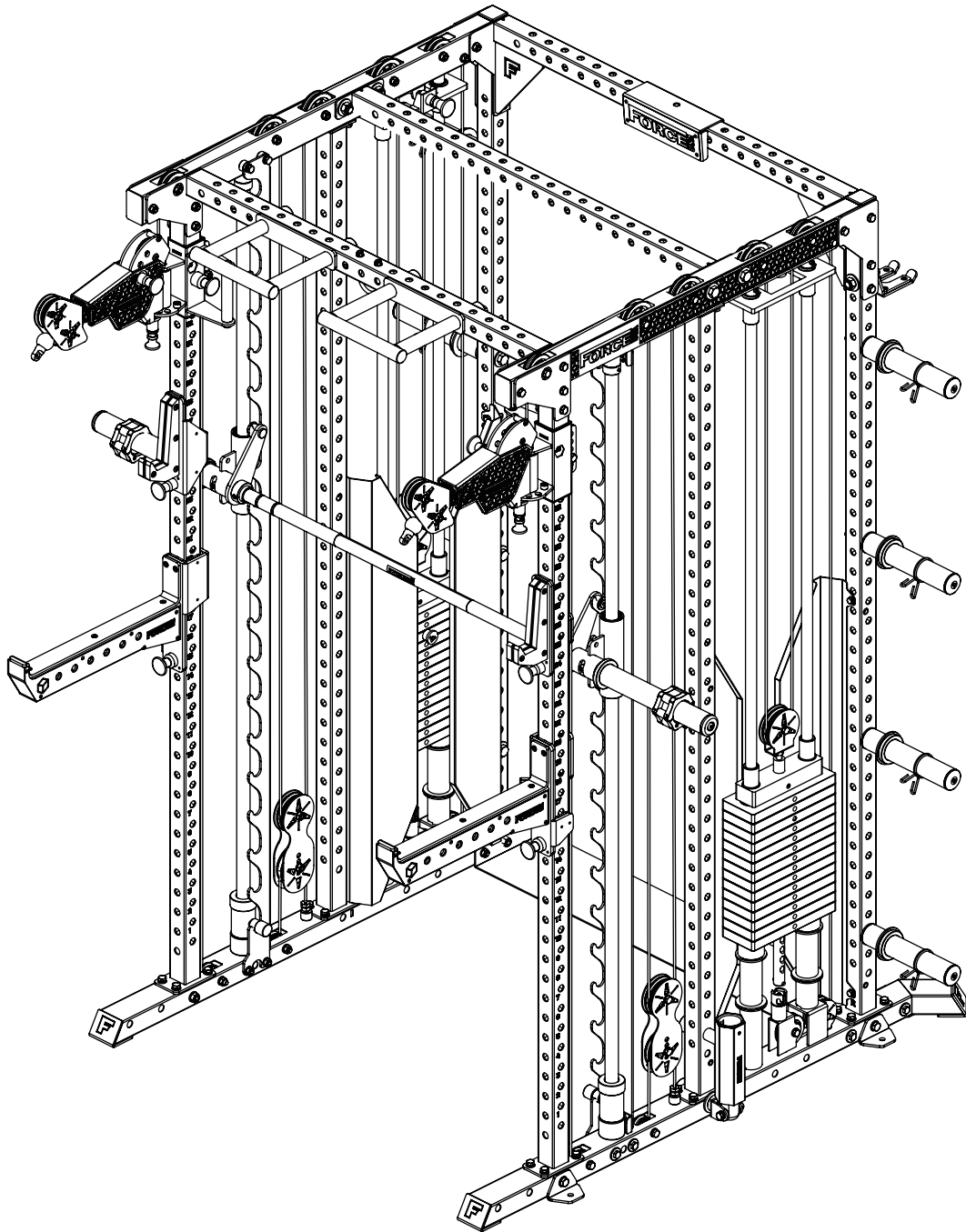

USER MANUAL | **F-M10**



THANK YOU FOR YOUR PURCHASE

**For the most up to date info about using
your equipment and our latest support
videos, please visit:**

www.forceusa.com





TRAINING APP

Download now and get access to 400+ exercise tutorials, absolutely free!



DOWNLOAD THE APP



STAY FOCUSED

Enjoy a low-friction interface designed to keep you focused on your next set.

NEW WORKOUT PLANS

Loaded with a growing library of unique workouts. Hundreds of movement tutorials designed by our expert panel of coaches.

REWARD YOUR SUCCESS

See your results build after every session with the pyramid progress tracker. Feel the support and share your progress with family and friends.

HARDER IS GOOD

SMARTER IS BETTER

The Force USA Training App offers customized workout plans so that you can get the same results in half the time.

Learn more at app.forceusa.com



IMPORTANT SAFETY INSTRUCTIONS



Regular maintenance is key to ensuring your safety and extending the lifespan of your Force USA equipment. Following the cleaning and lubrication cycles detailed here prevents premature wear, helps avoid potential injuries, and ensures optimal performance.

1. General Readiness & Assembly

- **Read the Manual:** Read all instructions and warning labels before assembling or using this equipment. Keep these instructions for future reference.
- **Assembly Safety:** It is highly recommended that two or more people perform the assembly. Assemble on a flat, level surface.
- **Hardware:** During assembly, only tighten nuts and bolts loosely. Once fully assembled, tighten all hardware from the bottom up, working evenly around the unit.
- **Orientation:** "Left" and "right" refer to the perspective of standing in front of and facing the equipment.

2. Medical & Health Advisory

- **Consult a Physician:** Before starting any exercise program, consult your doctor, especially if you are over 35 or have pre-existing health conditions.
- **Listen to Your Body:** Stop immediately if you experience pain, dizziness, nausea, or shortness of breath.
- **Preparation:** Always stretch and warm up properly prior to using the equipment.

3. Environment & Workspace

- **Surface:** Use a flat, stable surface. Consider a mat to protect your flooring.
- **Clearance:** Maintain at least 3–5 feet (1–1.5 meters) of clearance around the unit to avoid obstacles or interference.
- **Storage:** Do not use or store the equipment outdoors or near water.

4. Proper Usage & Technique

- **Safe Interaction:** Keep hair, fingers, and clothing away from all moving parts. Tie back long hair and remove jewelry.
- **Technique:** Focus on correct form and controlled movements. Increase weight or intensity gradually.

- **Supervision:** Keep children and pets away from the equipment at all times. For heavy lifting, use a spotter.

5. Technical Maintenance & Inspection

(Refer to the Maintenance Checklist on page 6 for specific component care)

- **Pre-Use Inspection:** Ensure all parts are in working order before every session. Check for cracks, wear, or loose bolts.
- **Moving Parts:** Do not over-tighten components with a pivoting function; they must move freely.
- **Specific Lubrication:** Use only silicone spray for the Smith Bar and Guide Rods as specified. Never spray ball bearings with silicone, as this washes out the internal grease.
- **Cable Integrity:** Regularly check cables for proper tension and signs of fraying. Ensure the weight selector pin inserts smoothly.
- **Defective Parts:** Never operate the equipment if parts are worn or malfunctioning. Replace defective components immediately.

6. Daily Cleaning

- **Hygiene:** Wipe down the equipment after each use with a dry, non-abrasive cloth to remove sweat and dust, preventing corrosion and material degradation.

BEFORE YOU START CONTINUED

MAINTENANCE CHECKLIST FOR FITNESS EQUIPMENT

• 1. Smith Bar

- Cleaning and Care
- The Smith bar must only be cleaned and lubricated with silicone spray.
- Manufacturer recommendation: CardioStrong silicone spray (FitShop).
- **Procedure:**
- Spray the bar generously with silicone spray.
- Wipe thoroughly with a dry, clean cloth.
- Repeat the process until the bar is completely clean.
- Finally, spray the bar again and leave the silicone spray on the surface as a protective and lubricating layer.

• Maintenance Interval

- Especially important before first use.
- Inspect every 4–6 weeks.
- Reapply if the bar appears dry.
- A light lubricating film should always be present on the bar.

• 2. Weight Stack Guide Rods

- Cleaning and Care
- The guide rods must only be cleaned and lubricated with silicone spray.
- Manufacturer recommendation: CardioStrong silicone spray (FitShop).
- **Procedure:**
- Spray the guide rod with silicone spray.
- Wipe with a dry cloth.
- Repeat until the rod is completely clean.
- Spray again and leave the product on the surface as a protective and lubricating layer.

• Maintenance Interval

- Especially important before first use.
- Inspect every 4–6 weeks.
- Reapply if the surface appears dry.
- A light lubricating film must be present at all times.

• 3. Machine Ball Bearings

• Important Notes

- Ball bearings must not be sprayed with

silicone spray, as this may wash out the existing bearing grease.

- Maintenance should be performed once per year.
- Use penetrating grease for servicing.
- Apply penetrating grease directly to the ball bearings once per year.

4. Cables

Inspection and Adjustment

- Regularly check cables for proper tension and overall condition.
- If necessary, tighten the cable at one of the adjustment points.
- The goal is to ensure that the weight selector pin can be inserted smoothly into every weight plate.
- If insertion is not possible, slightly loosen the cable accordingly.

Special Note – Freestyle Pulley

- Ensure that the cable at the rear of the Freestyle Pulley (front cable attachment)
 - either hangs straight down
 - or has slight play for movement.
- This prevents the formation of a predetermined breaking point.

Maintenance Schedule Overview

Maintenance Area	Maintenance Interval
Smith Bar	Every 4–6 weeks
Weight Stack Guide Rods	Every 4–6 weeks
Cables	Annually

HARDWARE IDENTIFIER

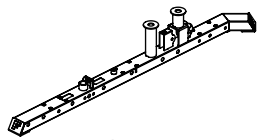

① x1

Base Frame - Right

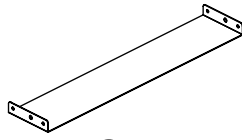

② x1

Connection Frame

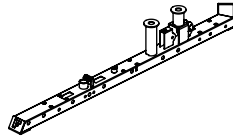

⑦ x1

Base Frame - Left

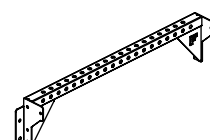

⑧ x1

Rear Top Connecting Frame

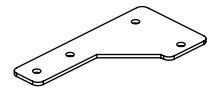

⑨ x2

Rear Top Support Bracket

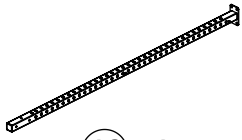

⑬ x1

Rear Right Upright

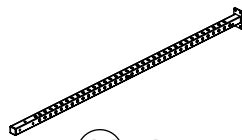

⑭ x1

Rear Left Upright

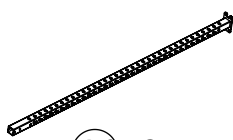

⑯ x2

Front Upright

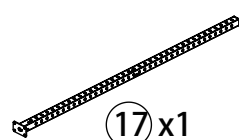

⑰ x1

Middle Right Upright

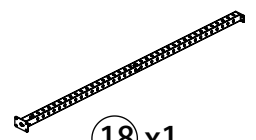

⑱ x1

Middle Left Upright

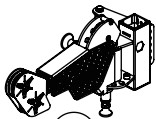

⑲ x1

Freestyle Trolley Right

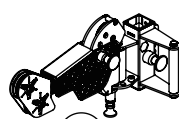

⑳ x1

Freestyle Trolley Left

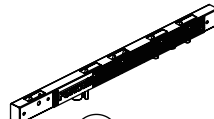

㉑ x1

Right Top Frame

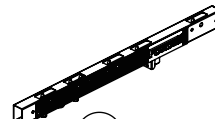

㉒ x1

Left Top Frame

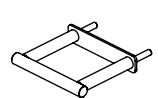

㉓ x2

Adjustable Pull Up Handle



㉔ x4

Knurled Nut



㉕ x2

Front Top Support Bracket

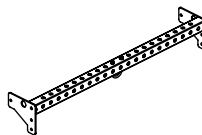

㉖ x1

Front Connection Frame

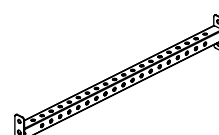

㉗ x1

Middle Connection Frame

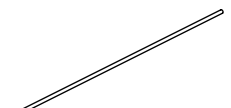

㉘ x4

Guide Rod



㉚ x4

Weight Stack Rubber Bumper

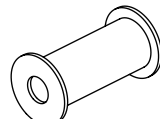

㉛ x4

Weight Stack Spacer

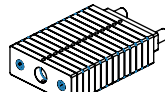

㉜ x2

Weight Stack

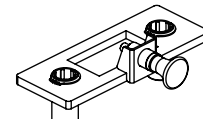

㉝ x2

2KG Incremental Weight Plate



㉞ x2

Pulley Frame

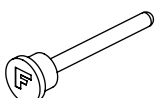

㉟ x2

Weight Stack Selector Pin

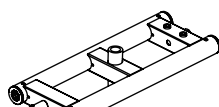

㊱ x2

Weight Plate Frame

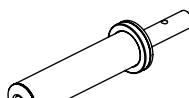

㊲ x4

Weight Plate Storage



㊳ x4

Spring Collar



㊴ x2

Upper Main Frame Cable



㊵ x2

Pulley Bracket

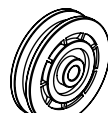

㊶ x8

75mm Pulley



㊷ x6

90mm Pulley



㊸ x6

50mm Pulley

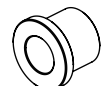

㊹ x24

Pulley Bushing



㊺ x2

Lower Main Frame Cable



㊻ x8

Pulley Bushing



㊼ x2

Smith Bar Guide Rod

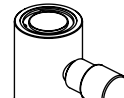

㊽ x2

Bottom Insert



㊾ x2

Smith Bar Safety Hook

HARDWARE IDENTIFIER



56 x2

Smith Bar Top Locking Sleeve

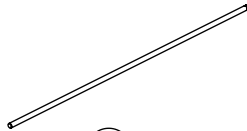

57 x2

Smith Bar Guide Rod

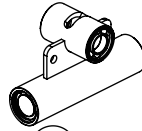

58 x2

Smith Bar Sliding Frame

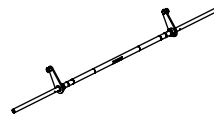

59 x1

Smith Bar

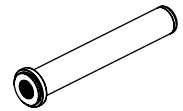

60 x2

Smith Barbell Sleeve



61 x2

Smith Barbell Sleeve Spacer

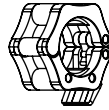

63 x2

Magnetic Olympic Lock Collar

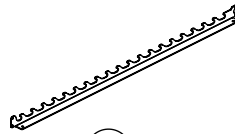

64 x1

Smith Bar Hook Plate - Right

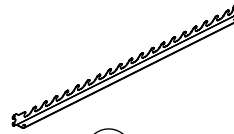

65 x1

Smith Bar Hook Plate - Left



68 x2

spacer sleeve

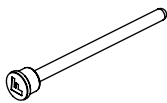

97 x4

Mag Pin

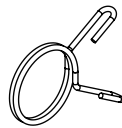

72 x8

Spring Collar

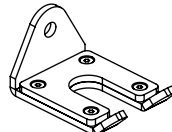

73 x1

Barbell Hanger

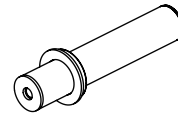

74 x8

Weight Plate Storage

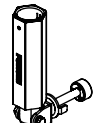

76 x1

Magnetic Landmine

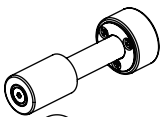

77 x1

Landmine Magnet

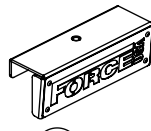

78 x1

LOGO Plate

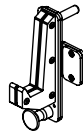

79 x1

J-Hook Right

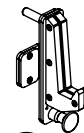

80 x1

J-Hook Left

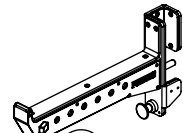

81 x1

Spotter Arm Right

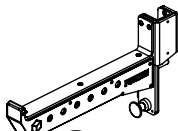

82 x1

Spotter Arm Left

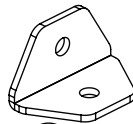

83 x4

Bracket L-Shape Floor

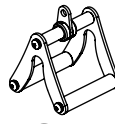

87 x1

Close Grip Triangle Landmine Handle



88 x2

Hook

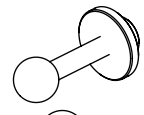

89 x4

Peg



90 x1

Ankle Cuff



91 x2

Single Knurled Handle

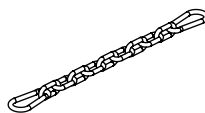

92 x4

Extension Chain



93 x1

Tricep Rope

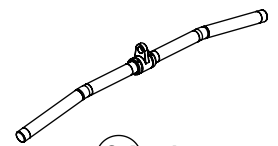

94 x1

Revolving Lat Pull Down Bar

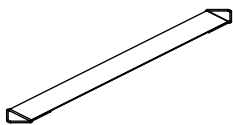

95 x1

Bodyweight Assisted Strap

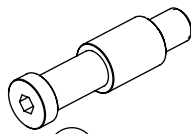

96 x8

Weight Stack Band Peg Hook

HARDWARE IDENTIFIER

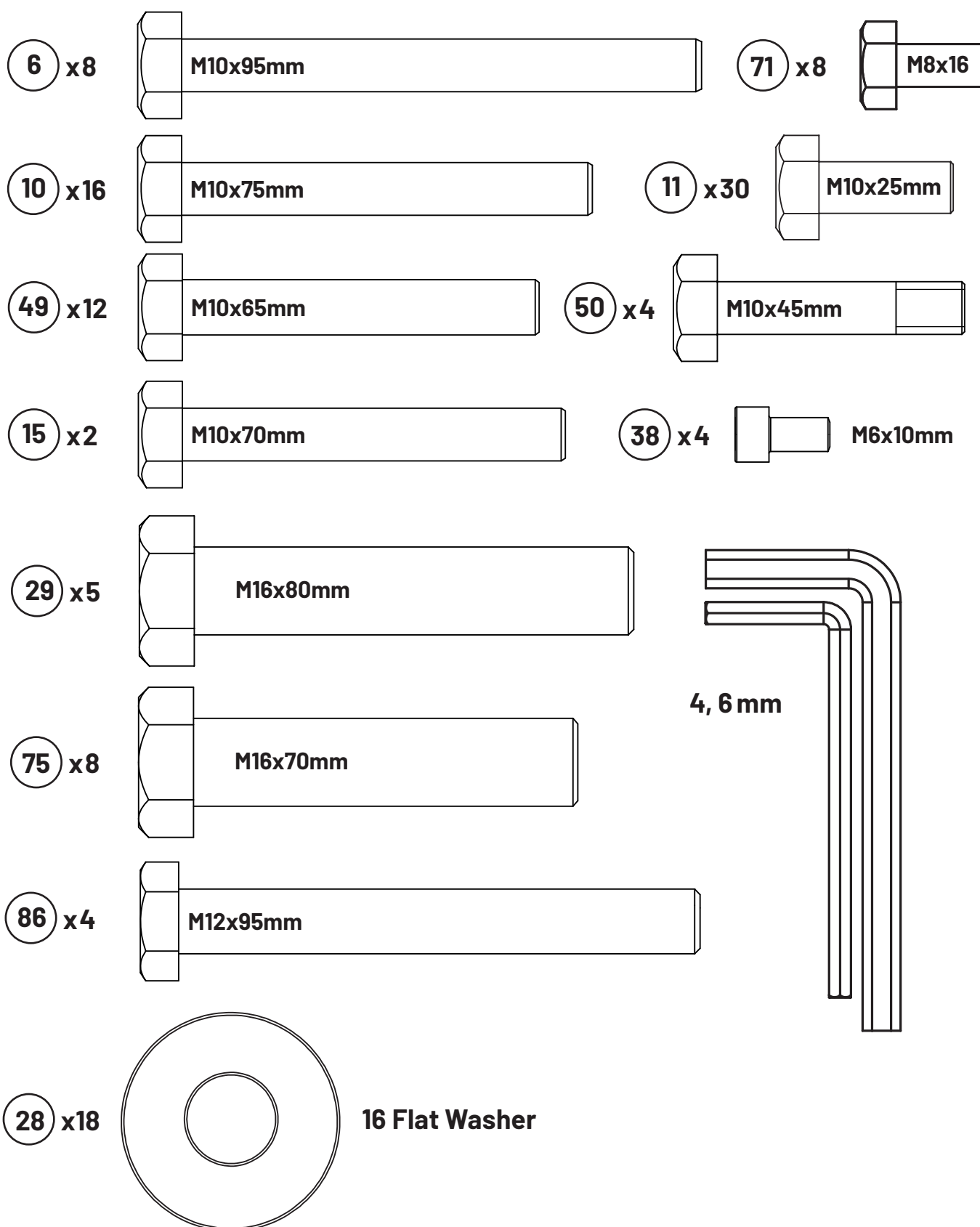

HARDWARE IDENTIFIER

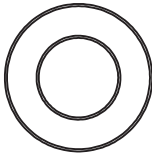
- 
4 x75 **10 Flat Washer**

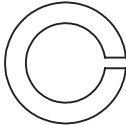
- 
12 x28 **10 Spring Washer**

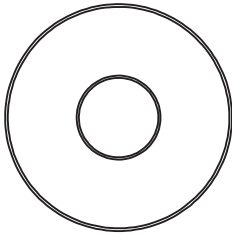
- 
3 x6 **Large Flat Washer**

- 
5 x41 **M10 Lock Nut**

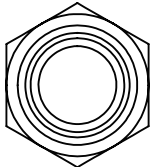
- 
85 x4 **M12 Lock Nut**

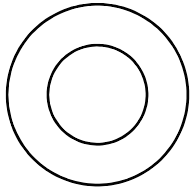
- 
84 x8 **12 Flat Washer**

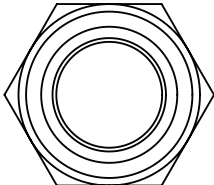
- 
30 x5 **M16 Lock Nut**

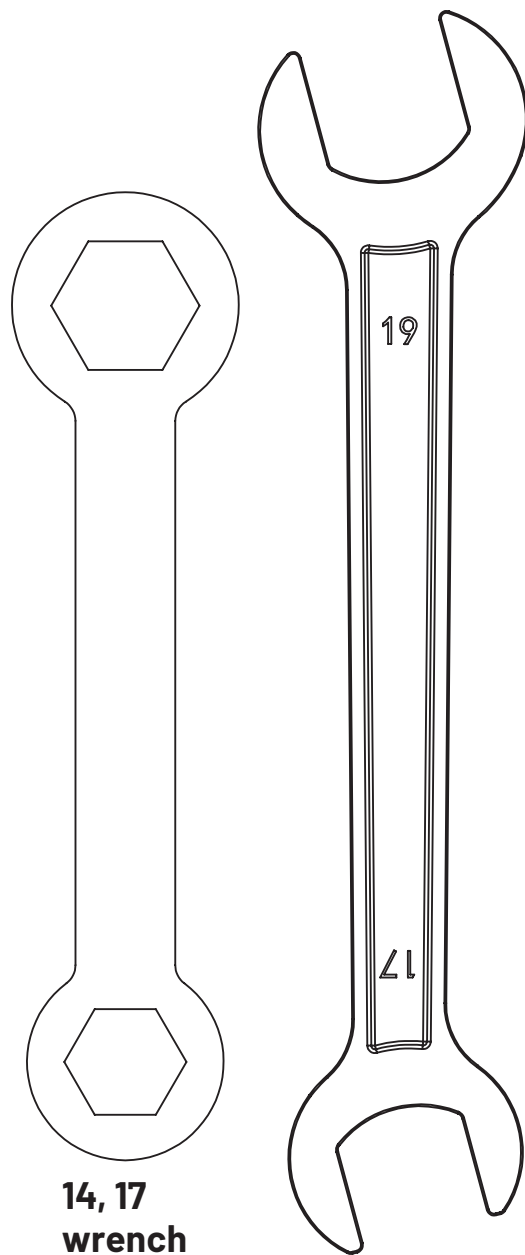

STEP1-PARTS & HARDWARE

Throughout this manual RIGHT and LEFT is defined as if you are standing in front of and facing the equipment.

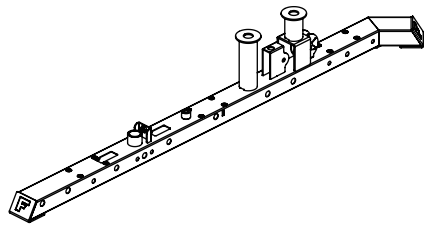

① x1
Base Frame - Right

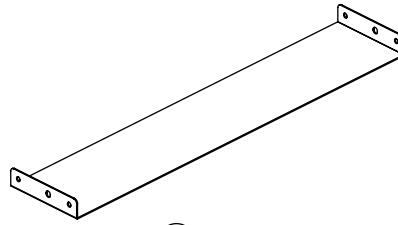

② x1
Connection Frame

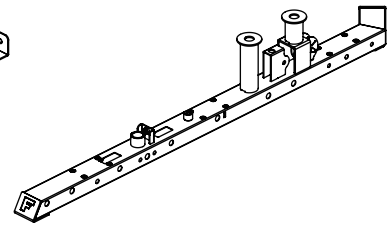

⑦ x1
Base Frame - Left



⑥ x4



④ x4

10 Flat Washer



⑤ x4

M10 Lock Nut

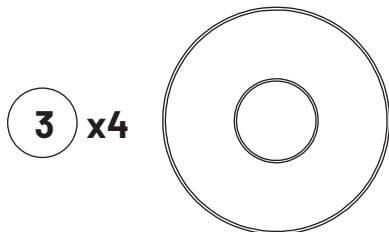

③ x4

Large Flat Washer

STEP1-ASSEMBLY



Hand tighten this step's hardware

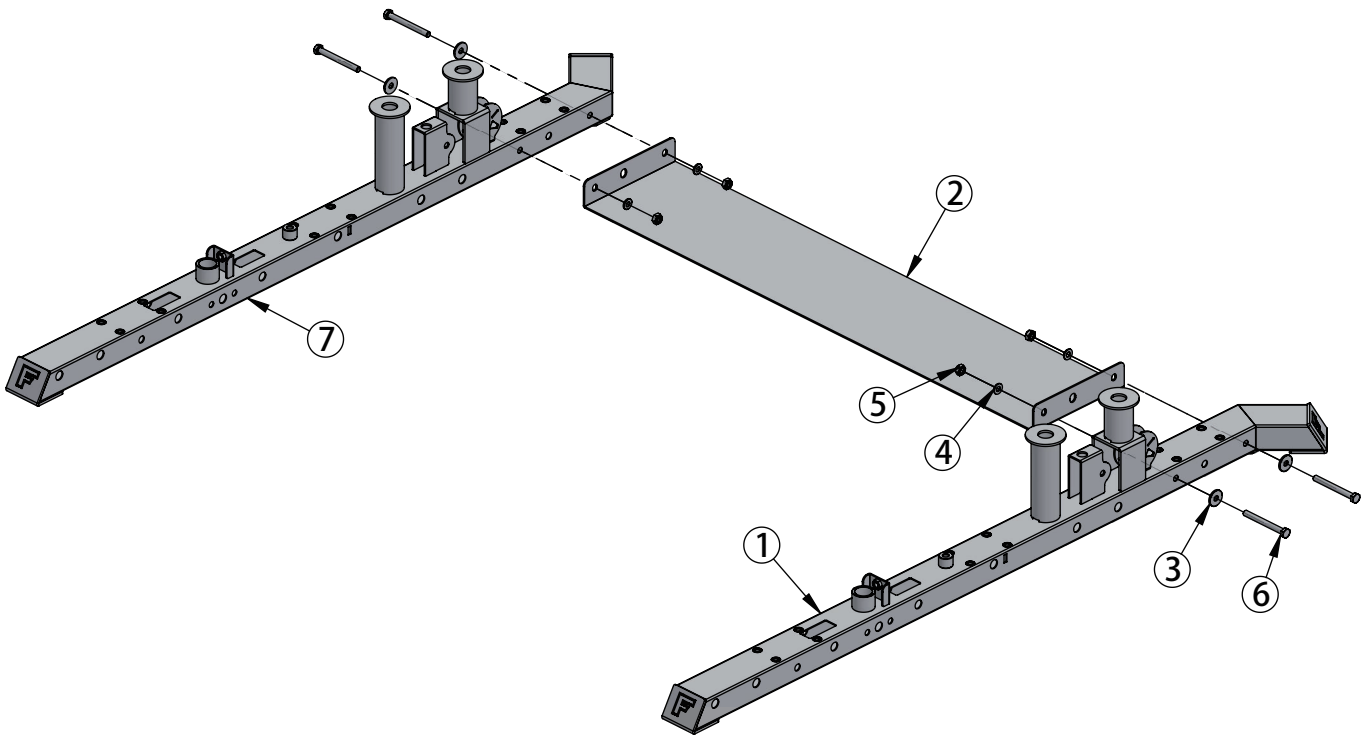

STEP2-PARTS & HARDWARE

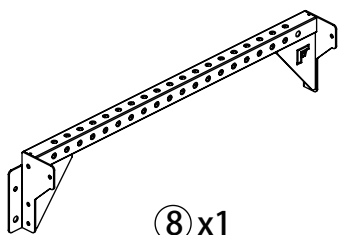

8 x1
Rear Top Connecting Frame

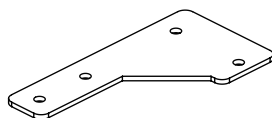

9 x2
Rear Top Support Bracket

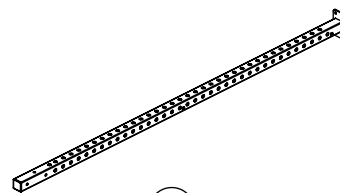

13 x1
Rear Right Upright

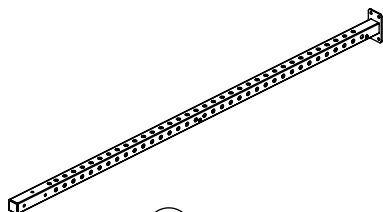

14 x1
Rear Left Upright

4 x20

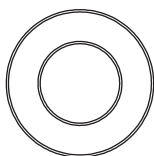

10 Flat Washer

5 x6

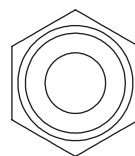

M10 Lock Nut

3 x2

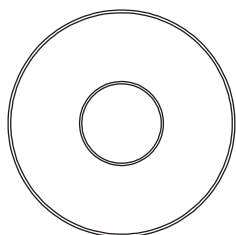

Large Flat Washer

12 x8



10 Spring Washer

10 x6

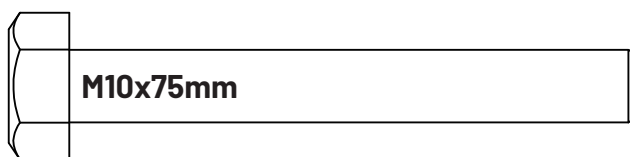

M10x75mm

11 x8

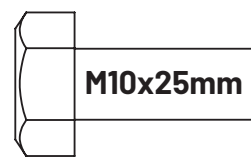

M10x25mm

15 x2

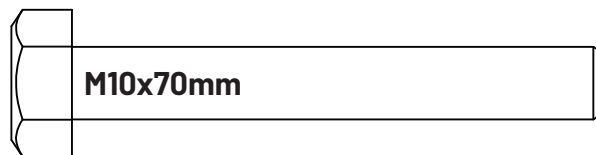

M10x70mm

STEP2-ASSEMBLY



Hand tighten this step's hardware

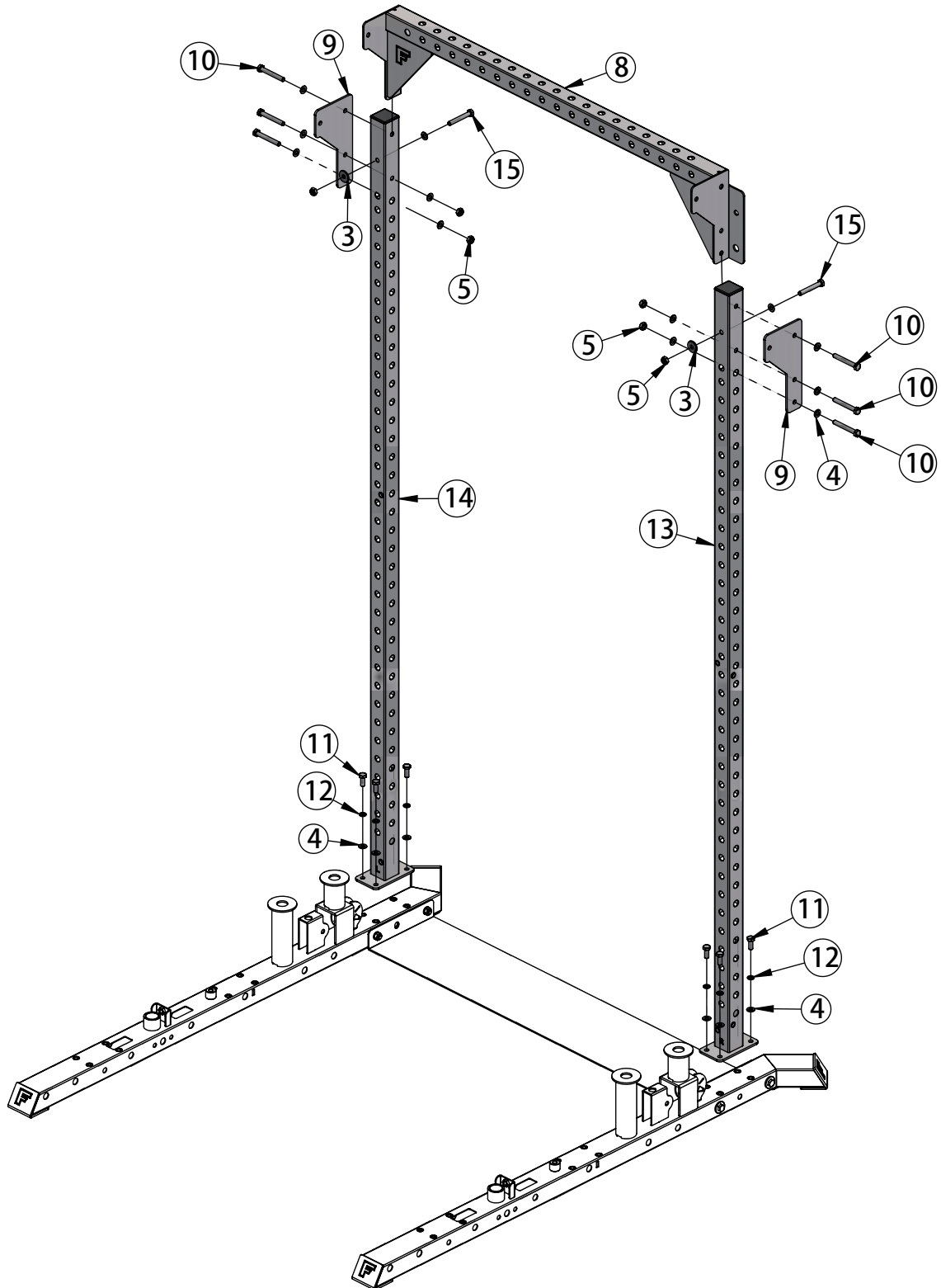

STEP3-PARTS & HARDWARE

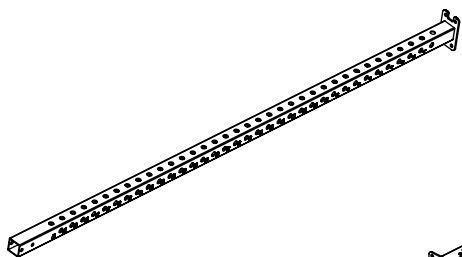

16 x2
Front Upright

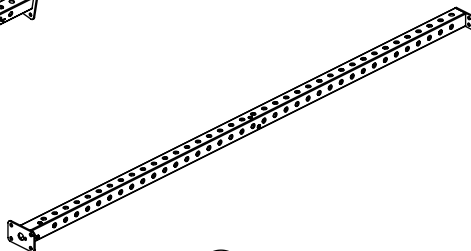

17 x1
Middle Right Upright

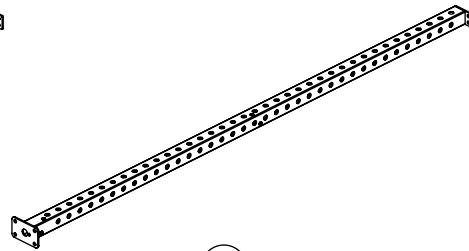

18 x1
Middle Left Upright

4 x16

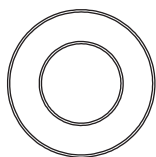

10 Flat Washer

12 x16



10 Spring Washer

11 x16

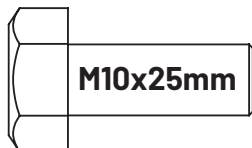

STEP3-ASSEMBLY



Hand tighten this step's hardware

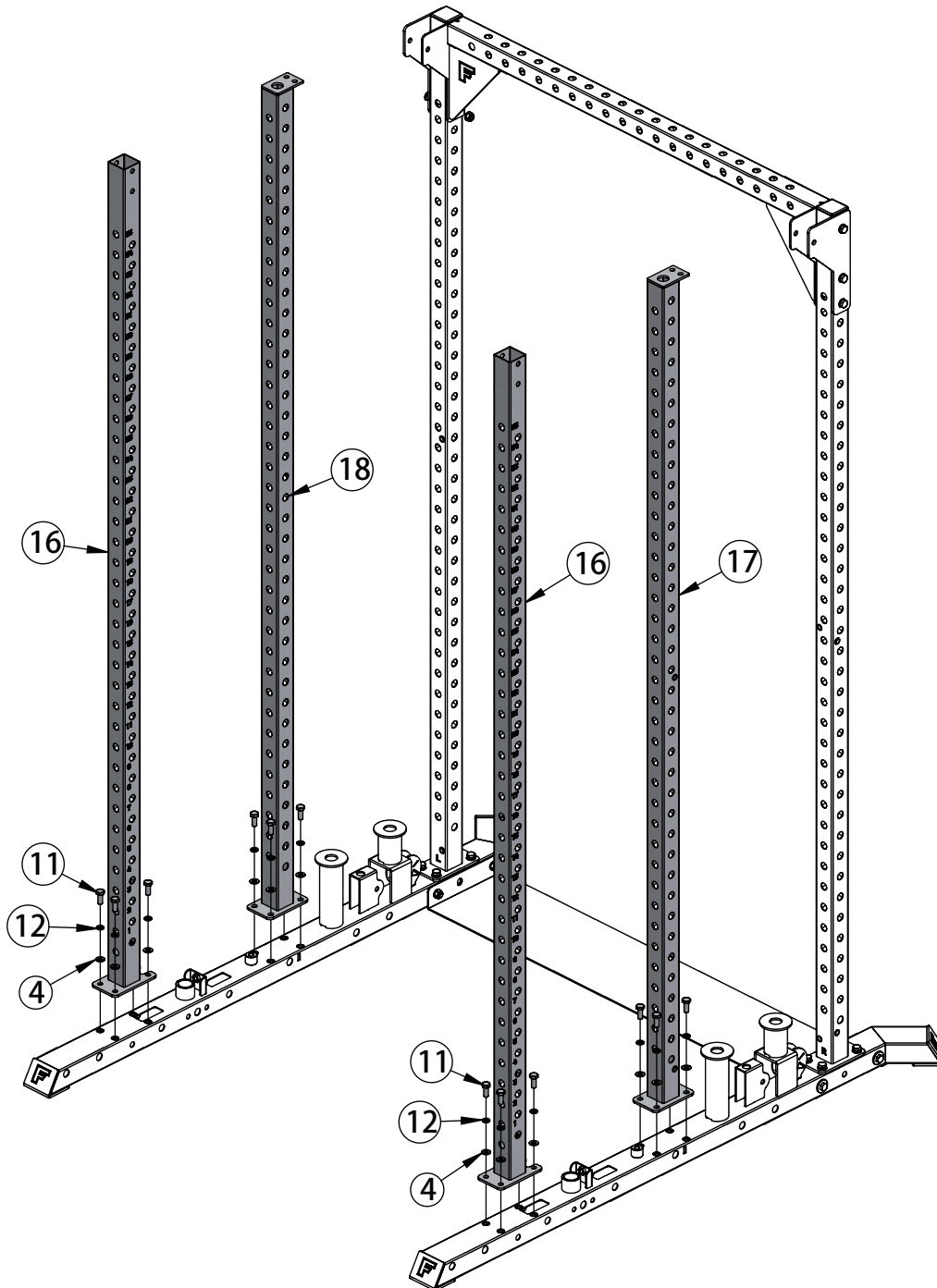

STEP4-PARTS & HARDWARE

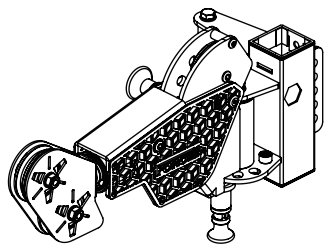

19 x1

Freestyle Trolley Right

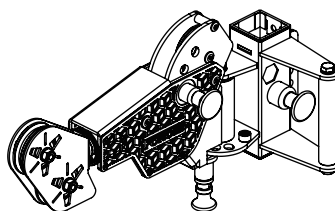

20 x1

Freestyle Trolley Left

STEP4-ASSEMBLY



Hand tighten this step's hardware

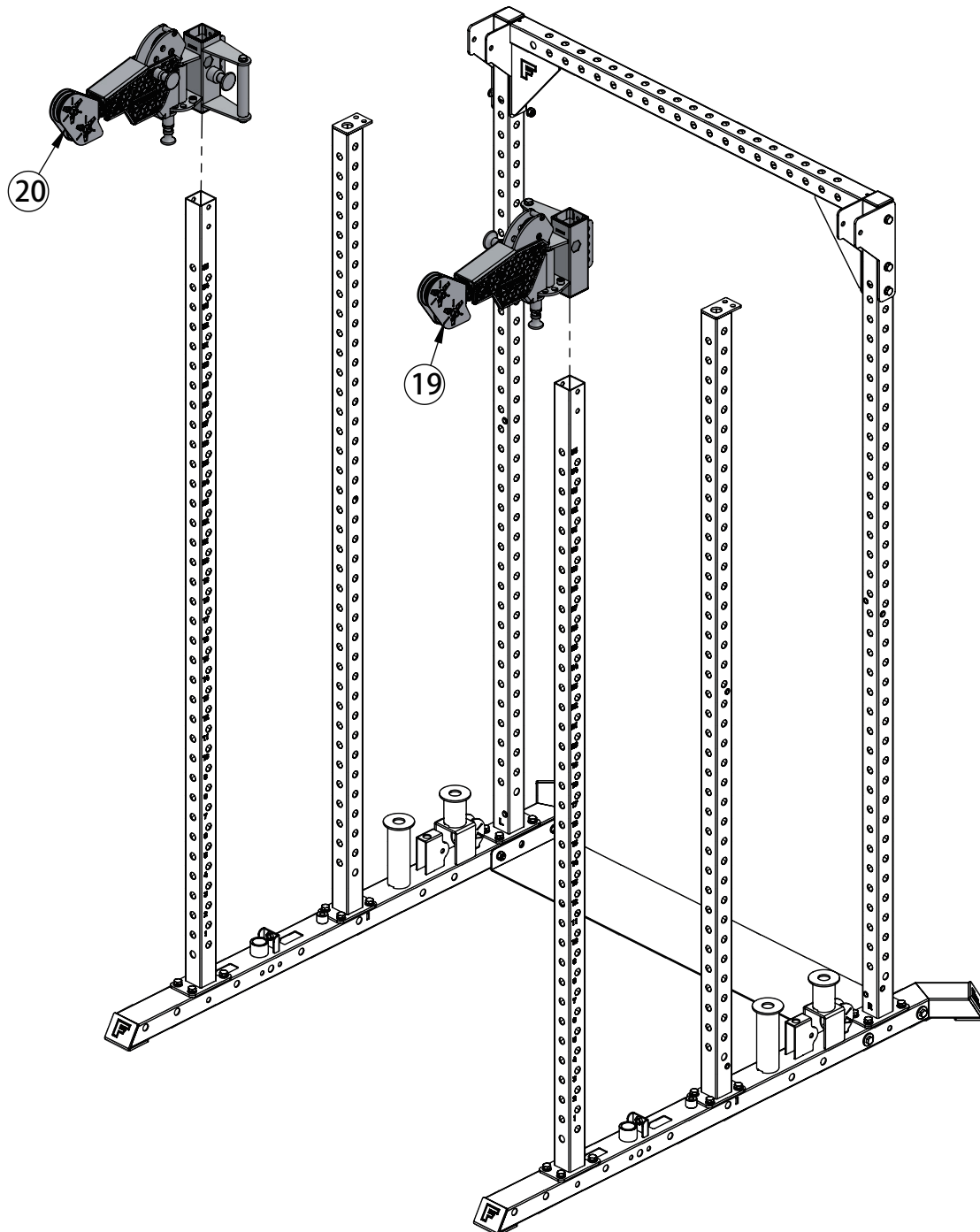

STEP5-PARTS & HARDWARE

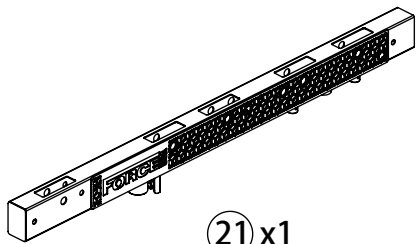

21 x1

Right Top Frame

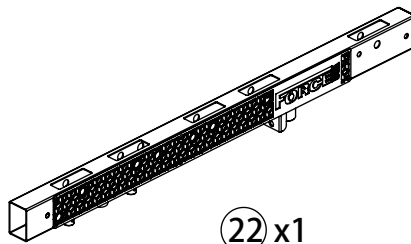

22 x1

Left Top Frame

4 x8

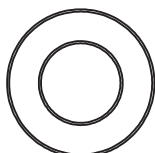

10 Flat Washer

5 x2

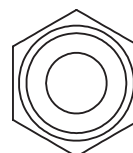

M10 Lock Nut

12 x4



10 Spring Washer

10 x2

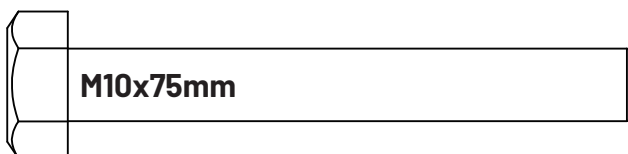

M10x75mm

11 x4

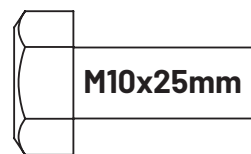

M10x25mm

STEP5-ASSEMBLY



Hand tighten this step's hardware

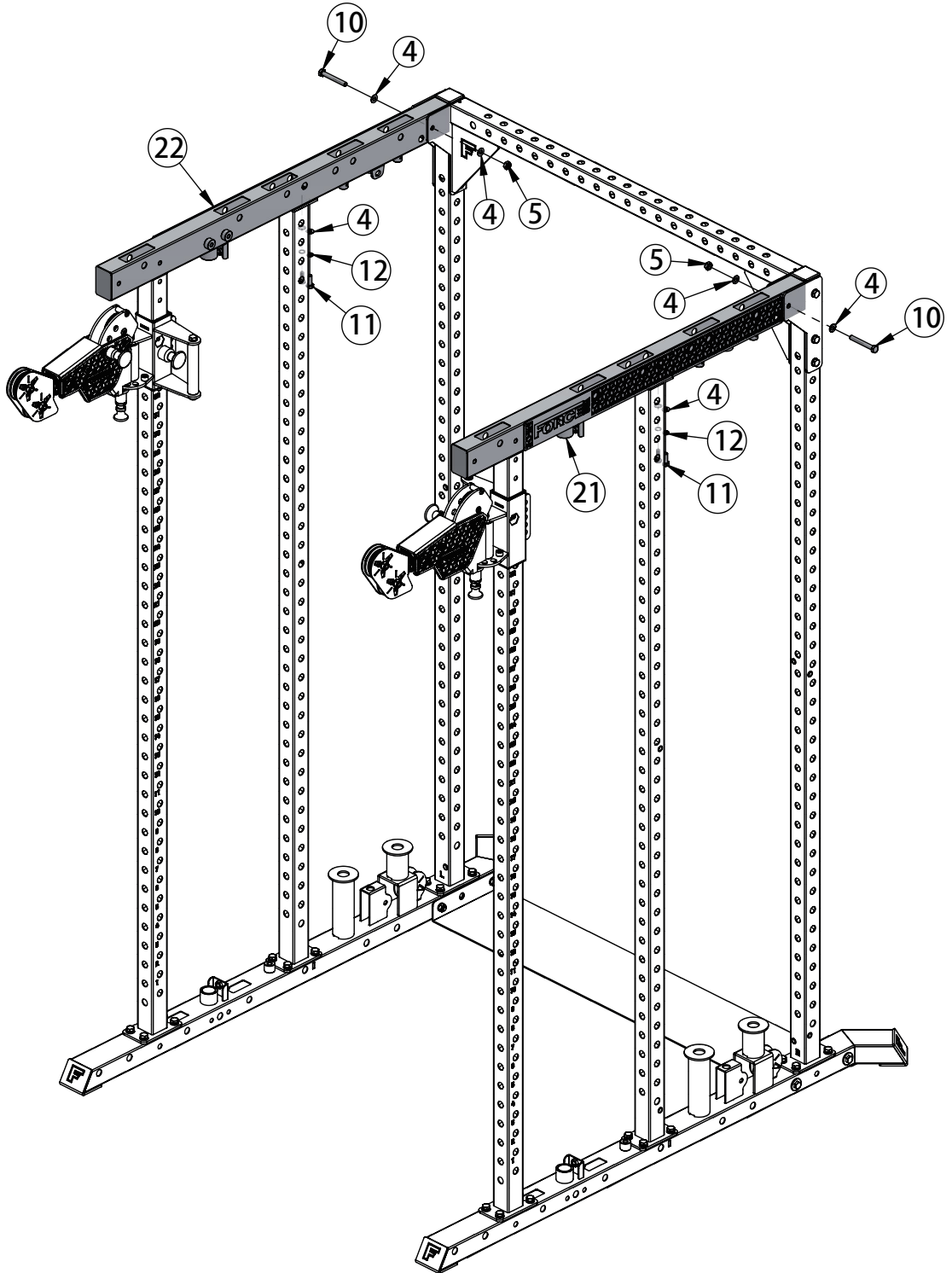

STEP6-PARTS & HARDWARE

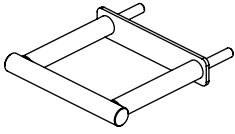

23 x2
Adjustable Pull Up Handle

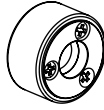

24 x4
Knurled Nut

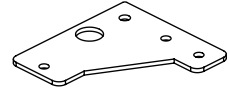

25 x2
Front Top Support Bracket

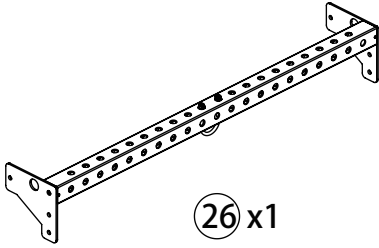

26 x1
Front Connection Frame

4 x14

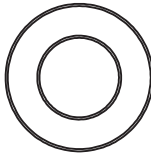

10 Flat Washer

5 x6



M10 Lock Nut

10 x8

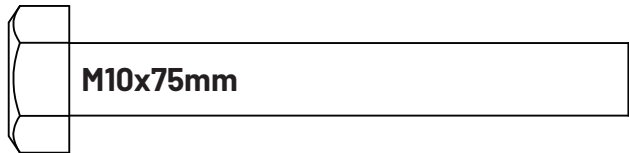

M10x75mm

STEP 6-ASSEMBLY



Hand tighten this step's hardware

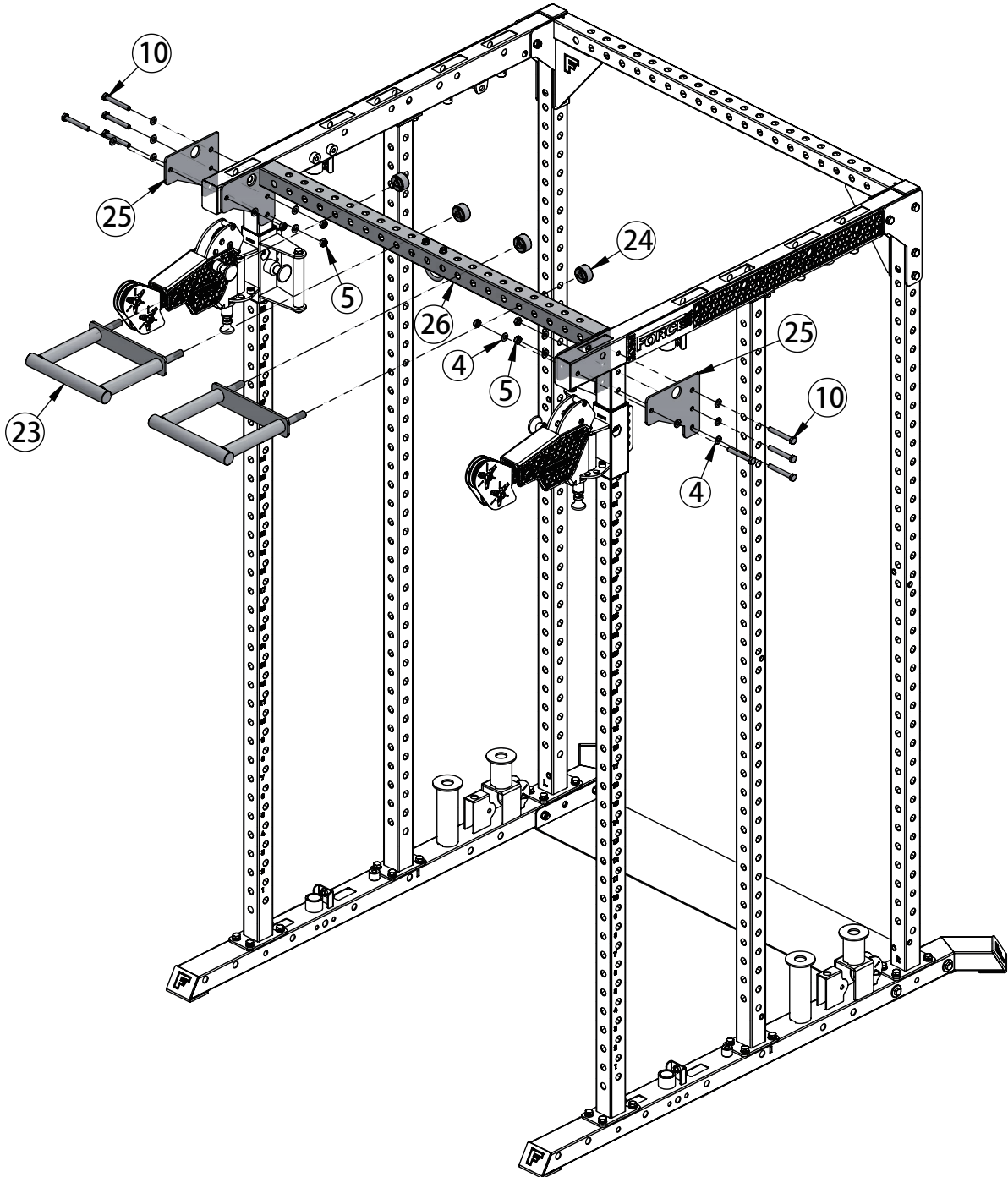

STEP7-PARTS & HARDWARE

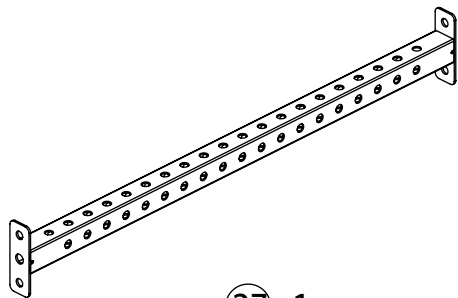

27 x1

Middle Connection Frame

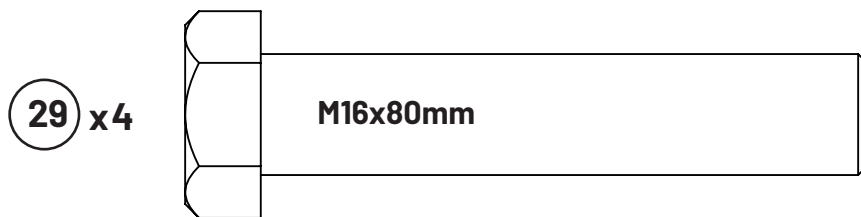

29 x4

M16x80mm

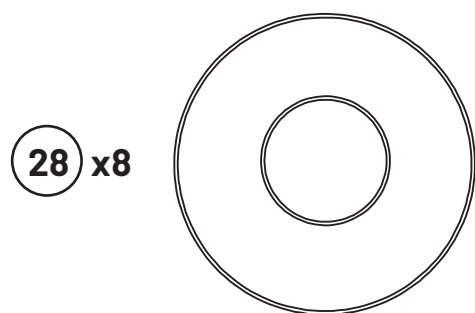

28 x8

16 Flat Washer



30 x4

M16 Lock Nut

STEP7-ASSEMBLY



Fully tighten this step's hardware

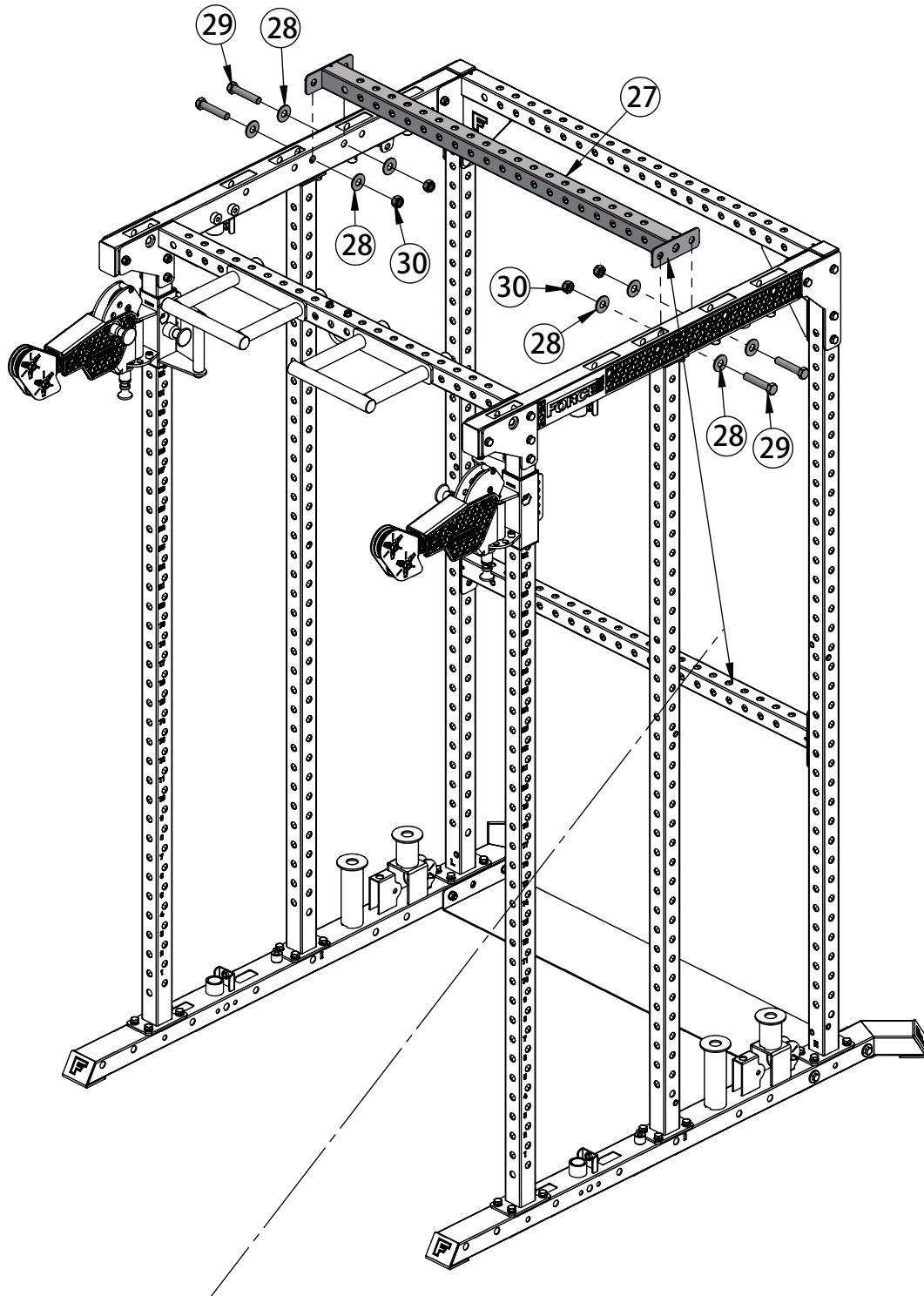

This component can be installed on the top or the back. Installing it on the back will be more stable.

STEP8-PARTS & HARDWARE

If you choose to assemble with the F-M10-PLC , please refer to the next step.

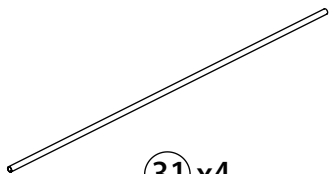

31 x4

Guide Rod

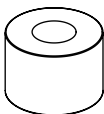

32 x4

Weight Stack Rubber Bumper

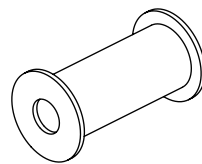

33 x4

Weight Stack Spacer

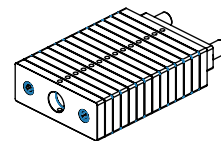

34 x2

Weight Stack

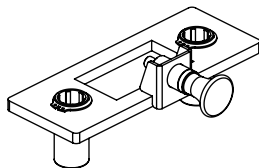

35 x2

2KG Incremental Weight Plate

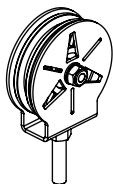

36 x2

Pulley Frame

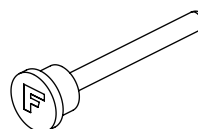

37 x2

Weight Stack Selector Pin

38 x4

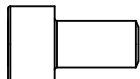

M6x10mm

STEP8-ASSEMBLY



Fully tighten this step's hardware

If you choose to assemble with the F-M10-PLC , please refer to the next step.

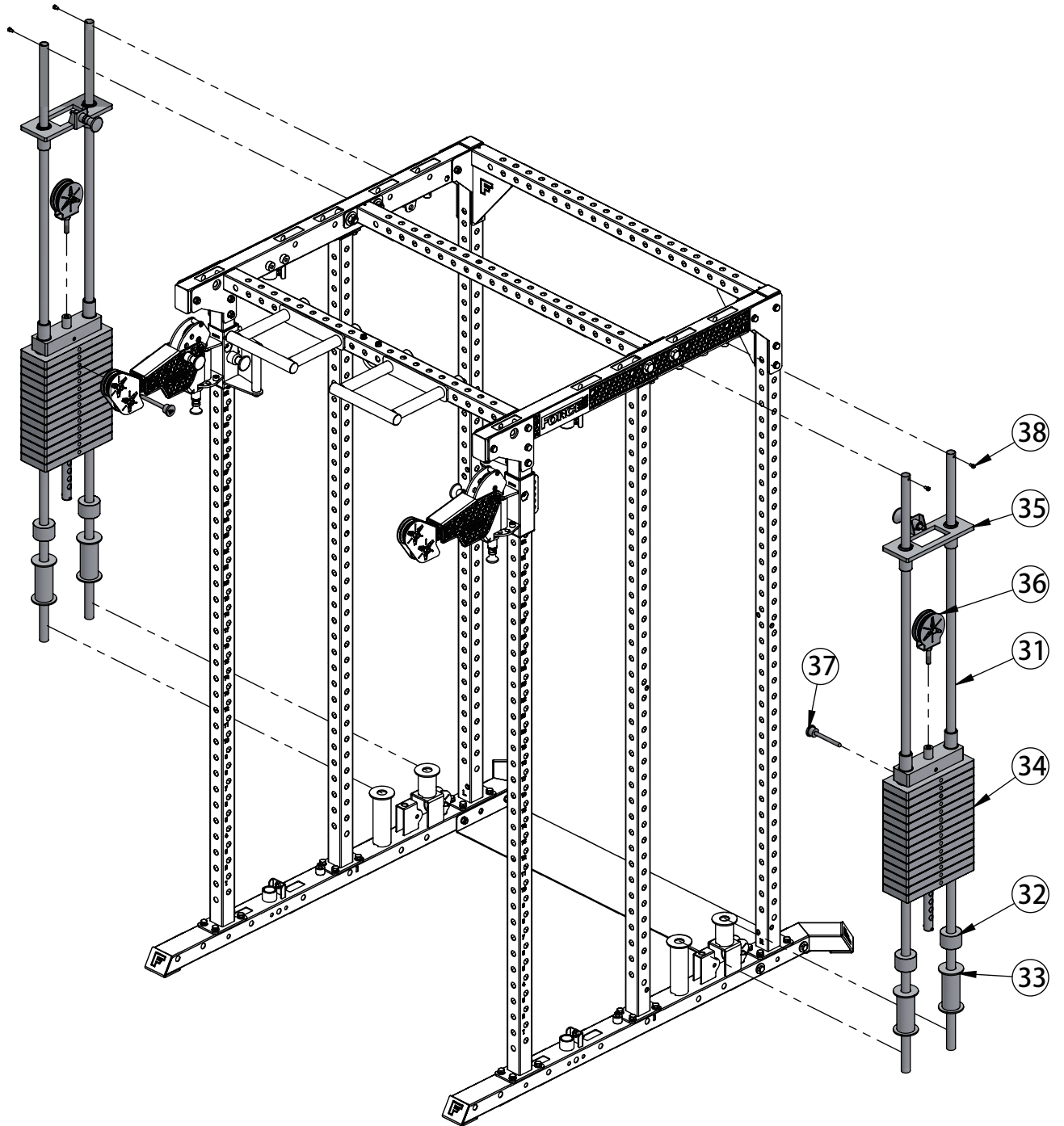

STEP9-PARTS & HARDWARE

If you choose to assemble with the F-M10-MS-150LBS , Please skip this step.

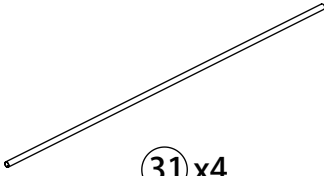

31 x4

Guide Rod

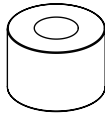

32 x4

Weight Stack Rubber Bumper

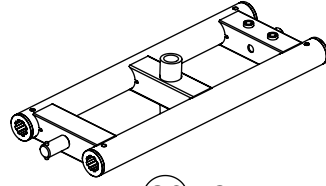

39 x2

Weight Plate Frame

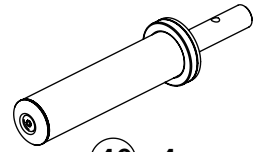

40 x4

Weight Plate Storage

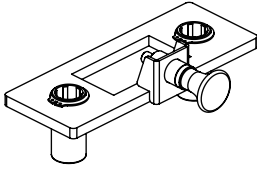

35 x2

2KG Incremental Weight Plate

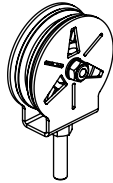

36 x2

Pulley Frame

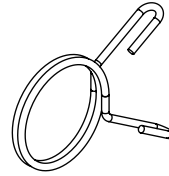

41 x4

Spring Collar

38 x4

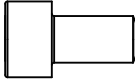

M6x10mm

42 x4



M8x10mm

STEP9-ASSEMBLY



Fully tighten this step's hardware

If you choose to assemble with the F-M10-MS-150LBS , Please skip this step.

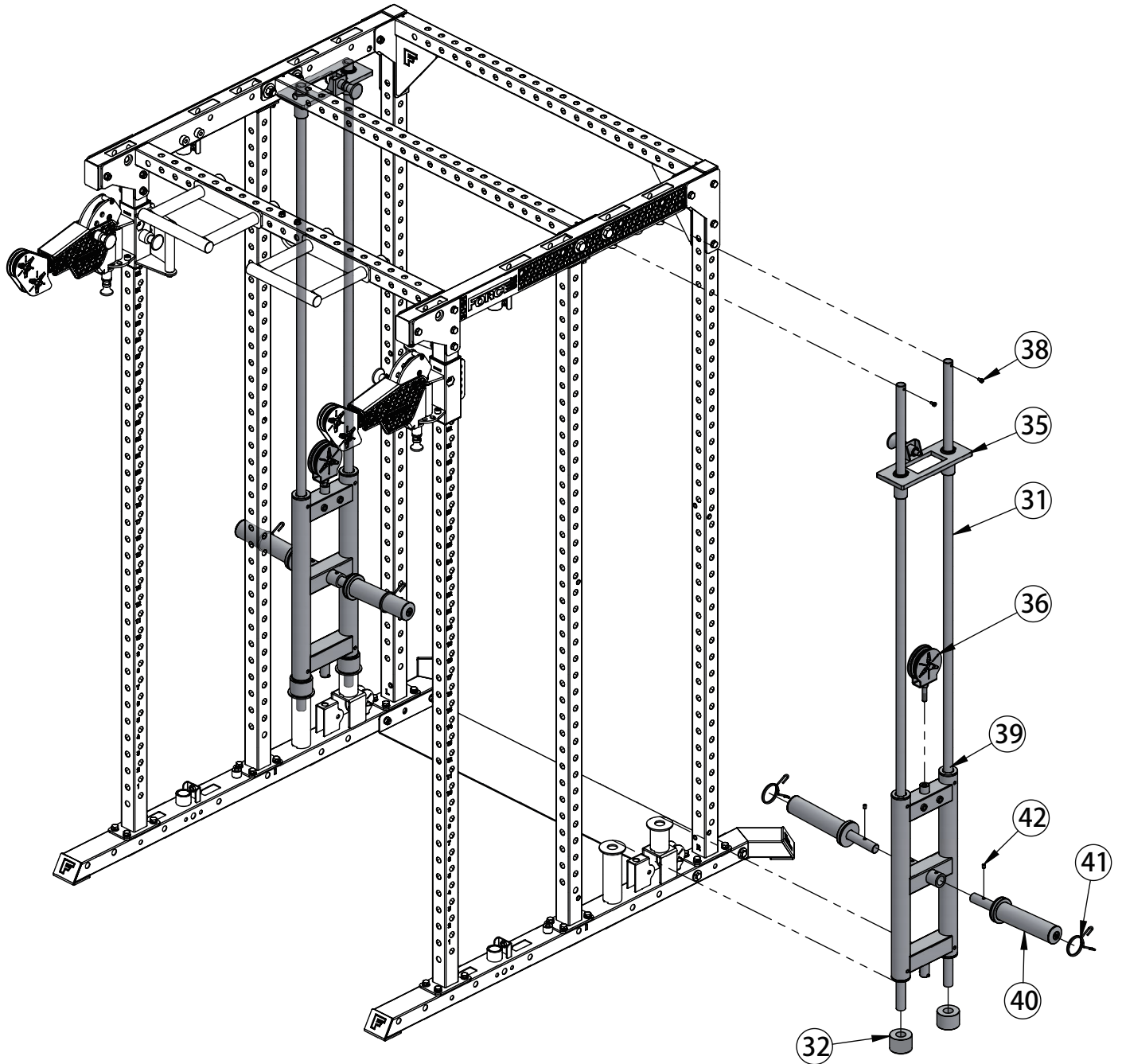

STEP10-PARTS & HARDWARE

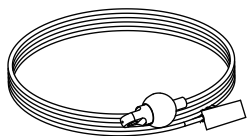

43 x2

Upper Main Frame Cable

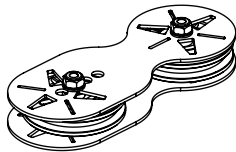

44 x2

Pulley Bracket



45 x8

75mm Pulley



46 x6

90mm Pulley



47 x2

50mm Pulley

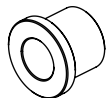

48 x24

Pulley Bushing

4 x8

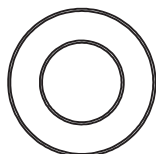

10 Flat Washer

5 x16

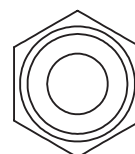

M10 Lock Nut

49 x12



M10x65mm

50 x4



M10x45mm

STEP10-ASSEMBLY



Fully tighten this step's hardware

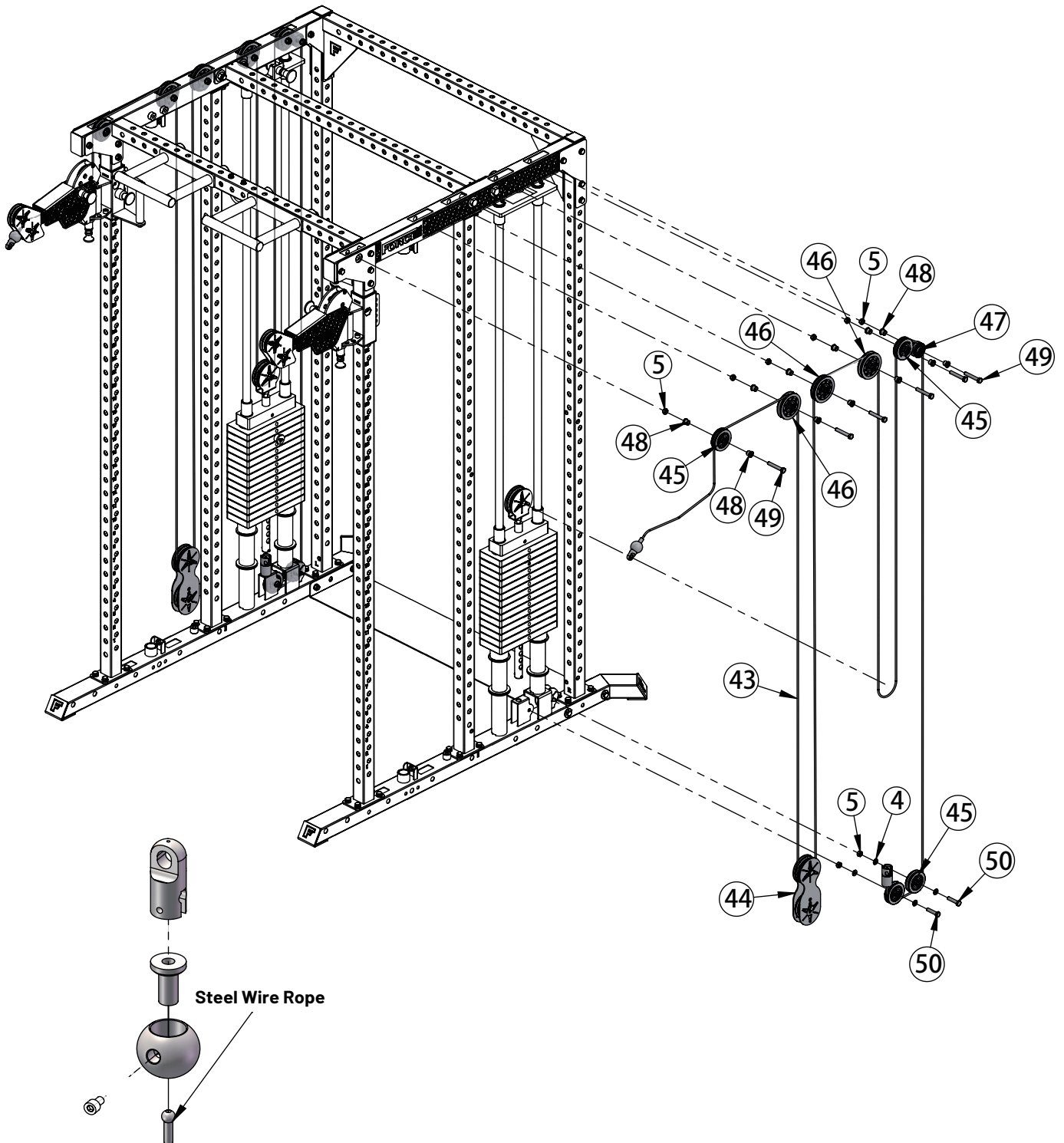

STEP10-ASSEMBLY



Fully tighten this step's hardware

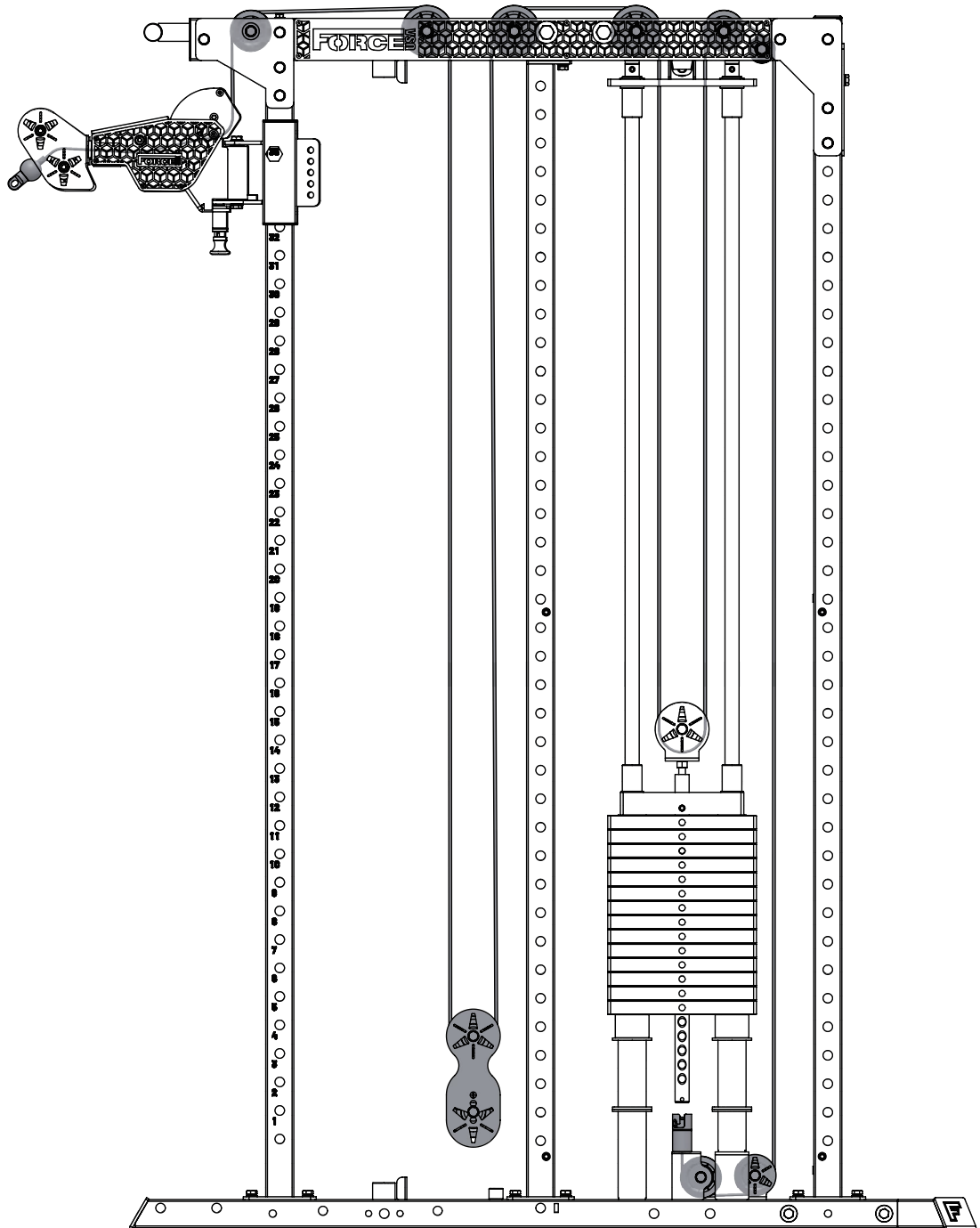

STEP11-PARTS & HARDWARE



47 x6
50mm Pulley

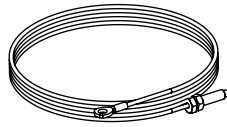

51 x2
Lower Main Frame Cable

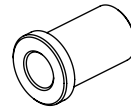

52 x8
Pulley Bushing

6 x4

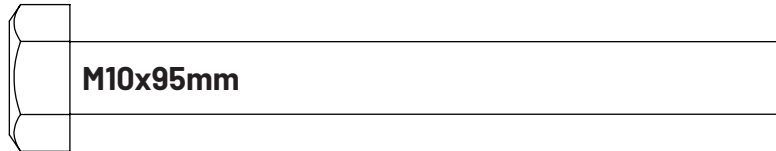

4 x4

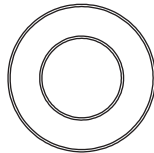

10 Flat Washer

5 x6

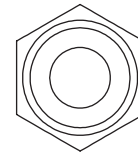

M10 Lock Nut

11 x2

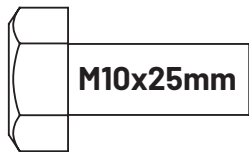

STEP11-ASSEMBLY



Fully tighten this step's hardware

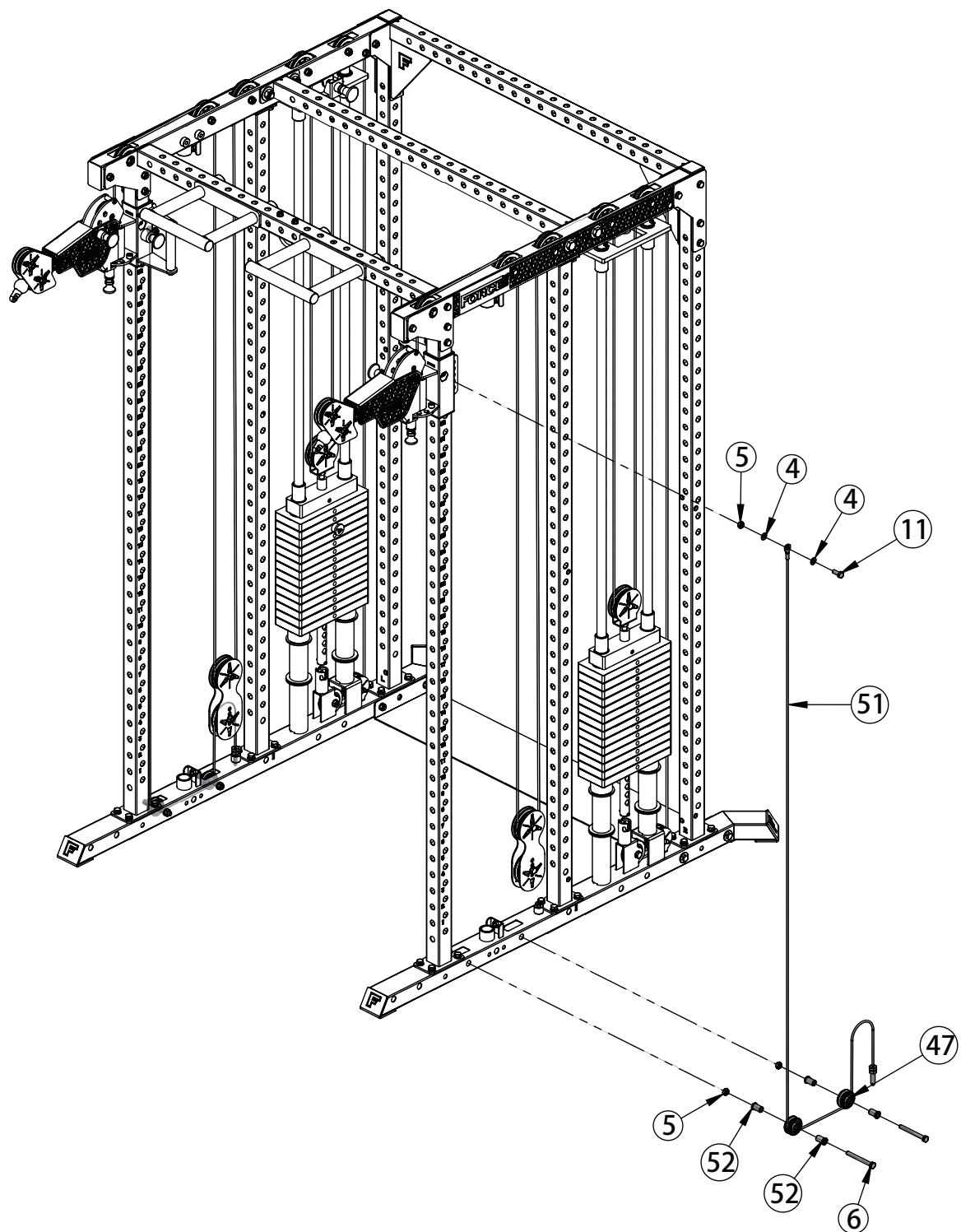

STEP11-ASSEMBLY



Fully tighten this step's hardware

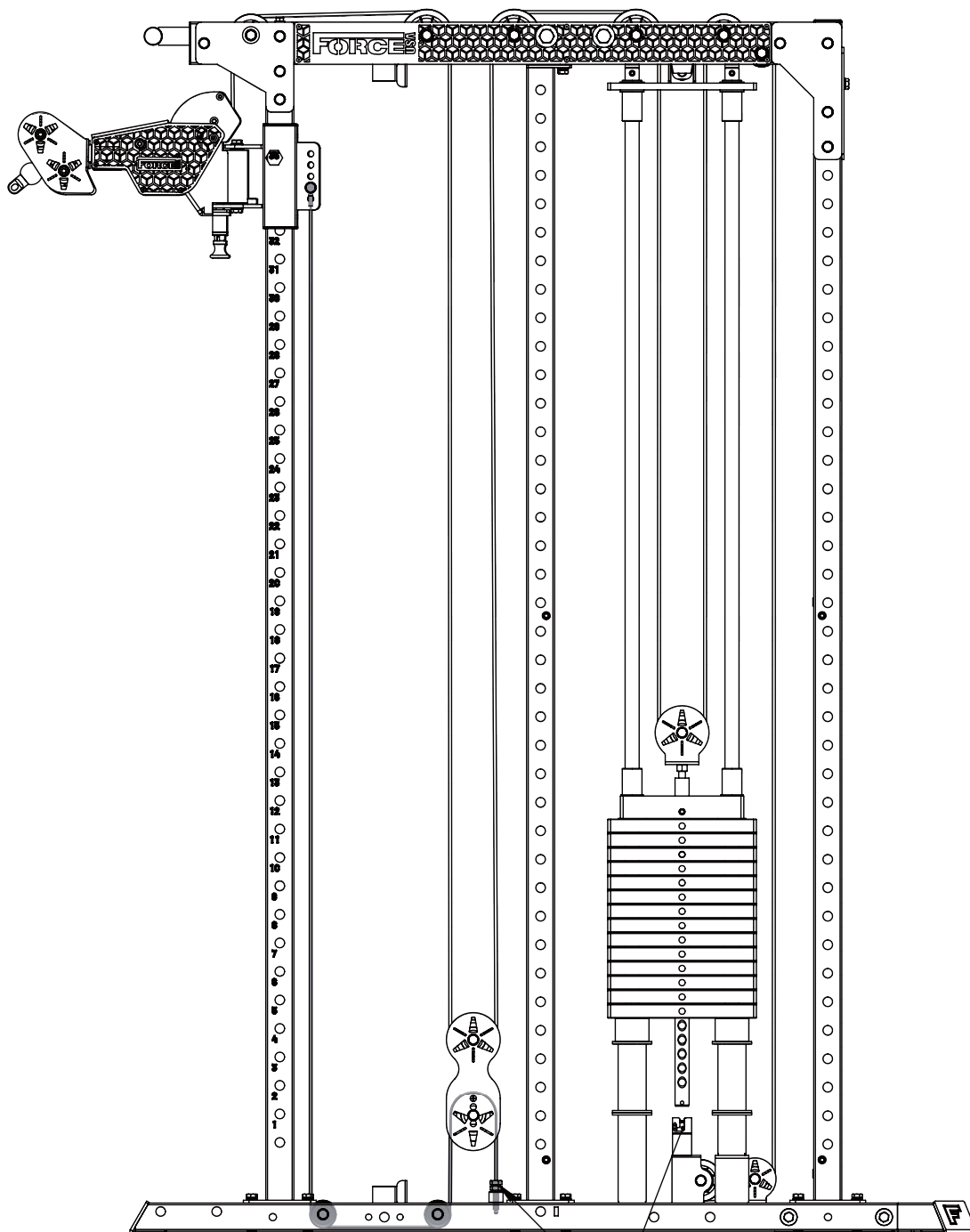

If the hanging sleeve is difficult to attach to the selector rod, please loosen the screw of the cable.

STEP12-PARTS & HARDWARE

If you haven't purchased the F-M10-SMITH, please skip this step.



53 x2

Smith Bar Guide Rod Bottom Insert

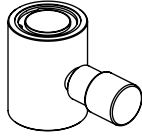

54 x2

Smith Bar Safety Hook

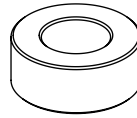

55 x2

Smith Bar Rubber Bumper



56 x2

Smith Bar Top Locking Sleeve

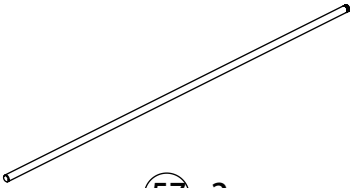

57 x2

Smith Bar Guide Rod

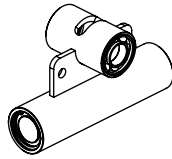

58 x2

Smith Bar Sliding Frame

42 x2



M8x10mm

STEP12-ASSEMBLY



Fully tighten this step's hardware

If you haven't purchased the F-M10-SMITH, please skip this step.

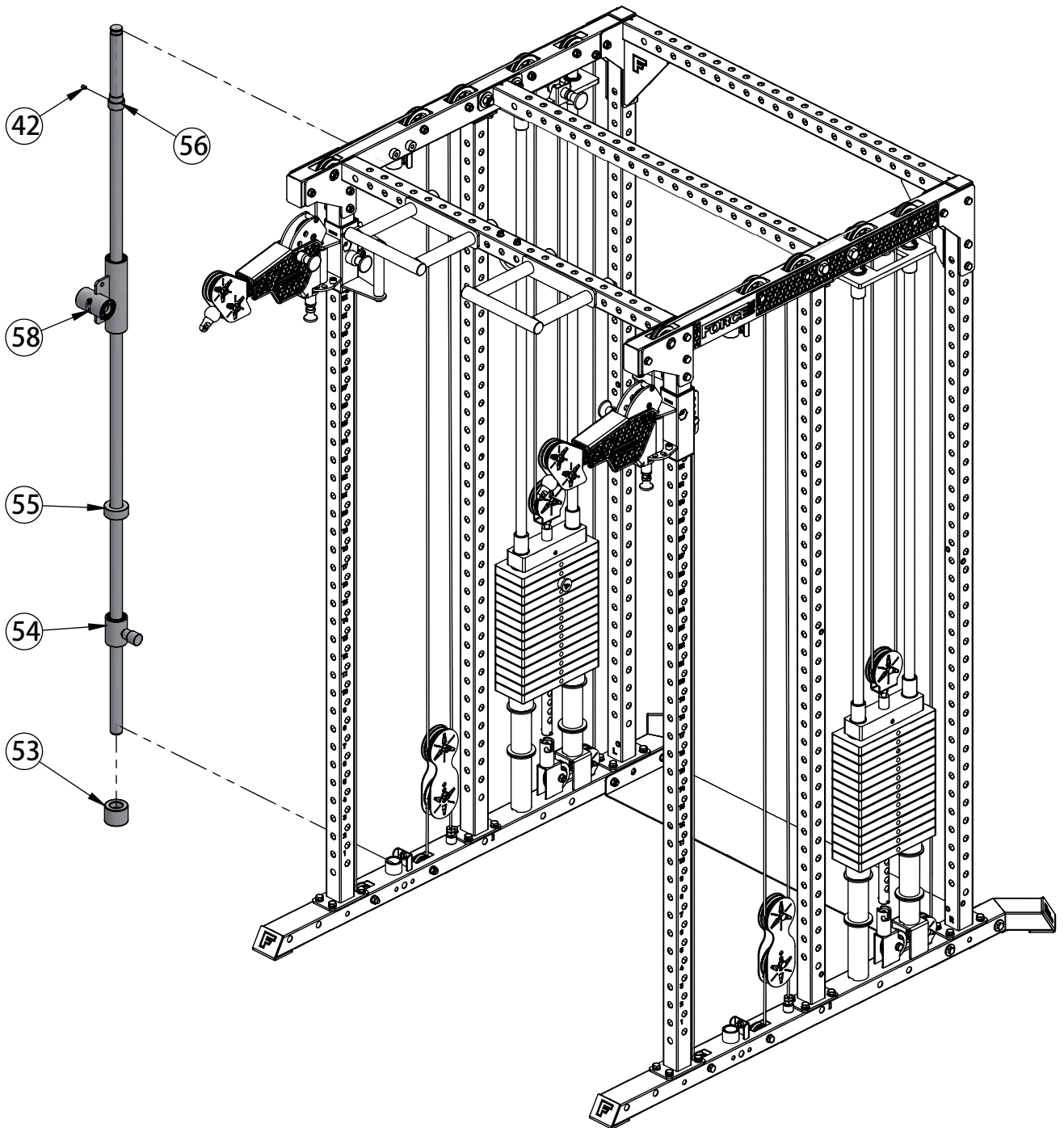

STEP13-PARTS & HARDWARE

If you haven't purchased the F-M10-SMITH, please skip this step.

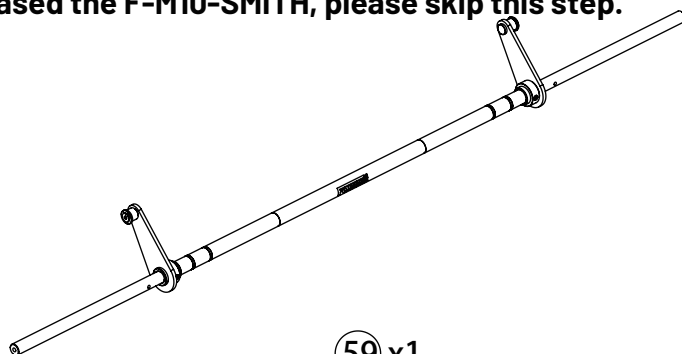

59 x1
Smith Bar

STEP13-ASSEMBLY



Fully tighten this step's hardware

If you haven't purchased the F-M10-SMITH, please skip this step.

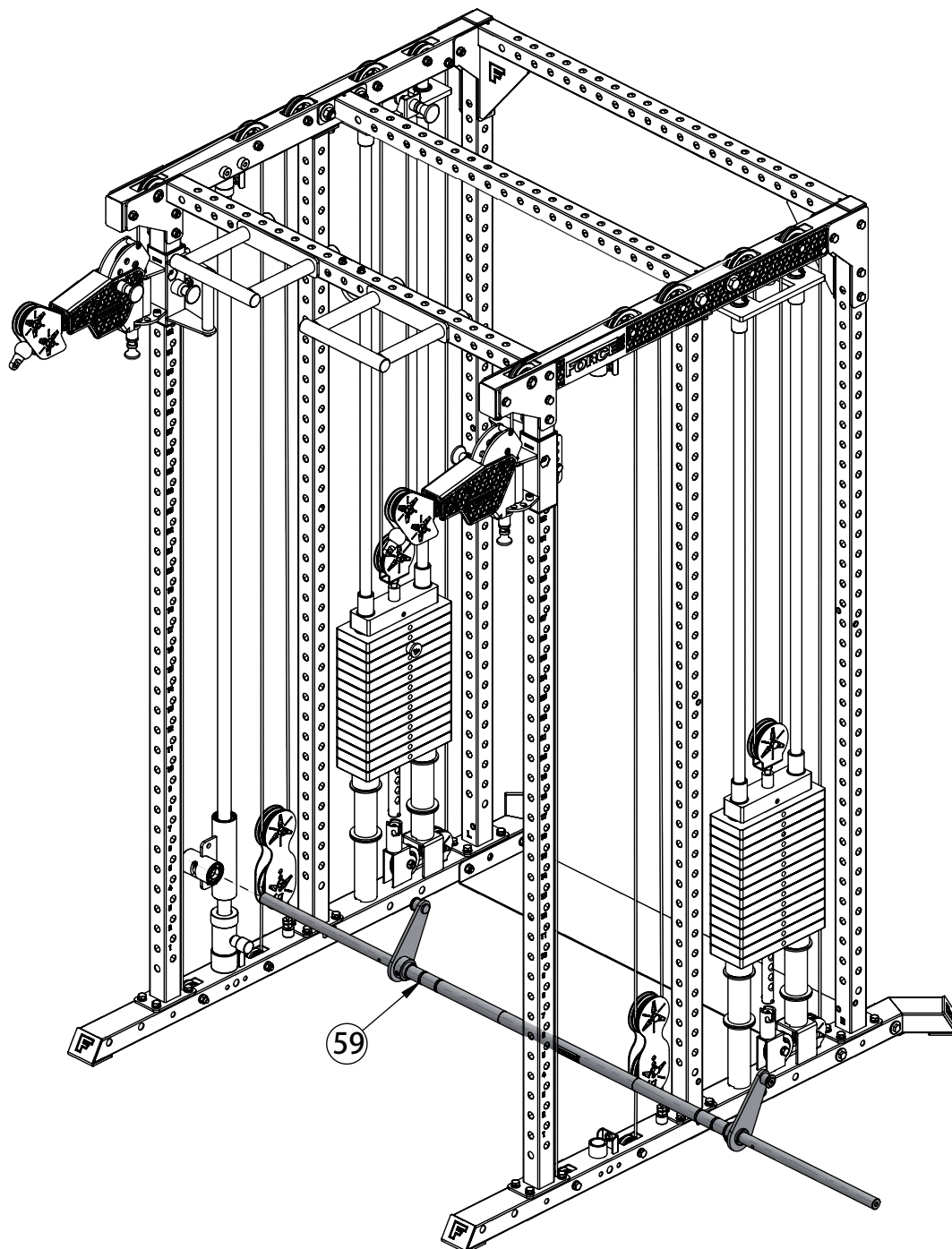

STEP14-PARTS & HARDWARE

If you haven't purchased the F-M10-SMITH, please skip this step.



53 x2

Smith Bar Guide Rod Bottom Insert



54 x2

Smith Bar Safety Hook

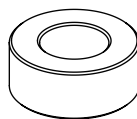

55 x2

Smith Bar Rubber Bumper

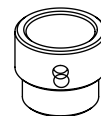

56 x2

Smith Bar Top Locking Sleeve

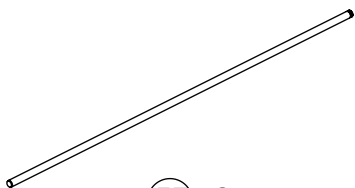

57 x2

Smith Bar Guide Rod

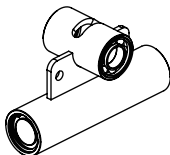

58 x2

Smith Bar Sliding Frame

42 x2



M8x10mm

STEP14-ASSEMBLY



Fully tighten this step's hardware

If you haven't purchased the F-M10-SMITH, please skip this step.

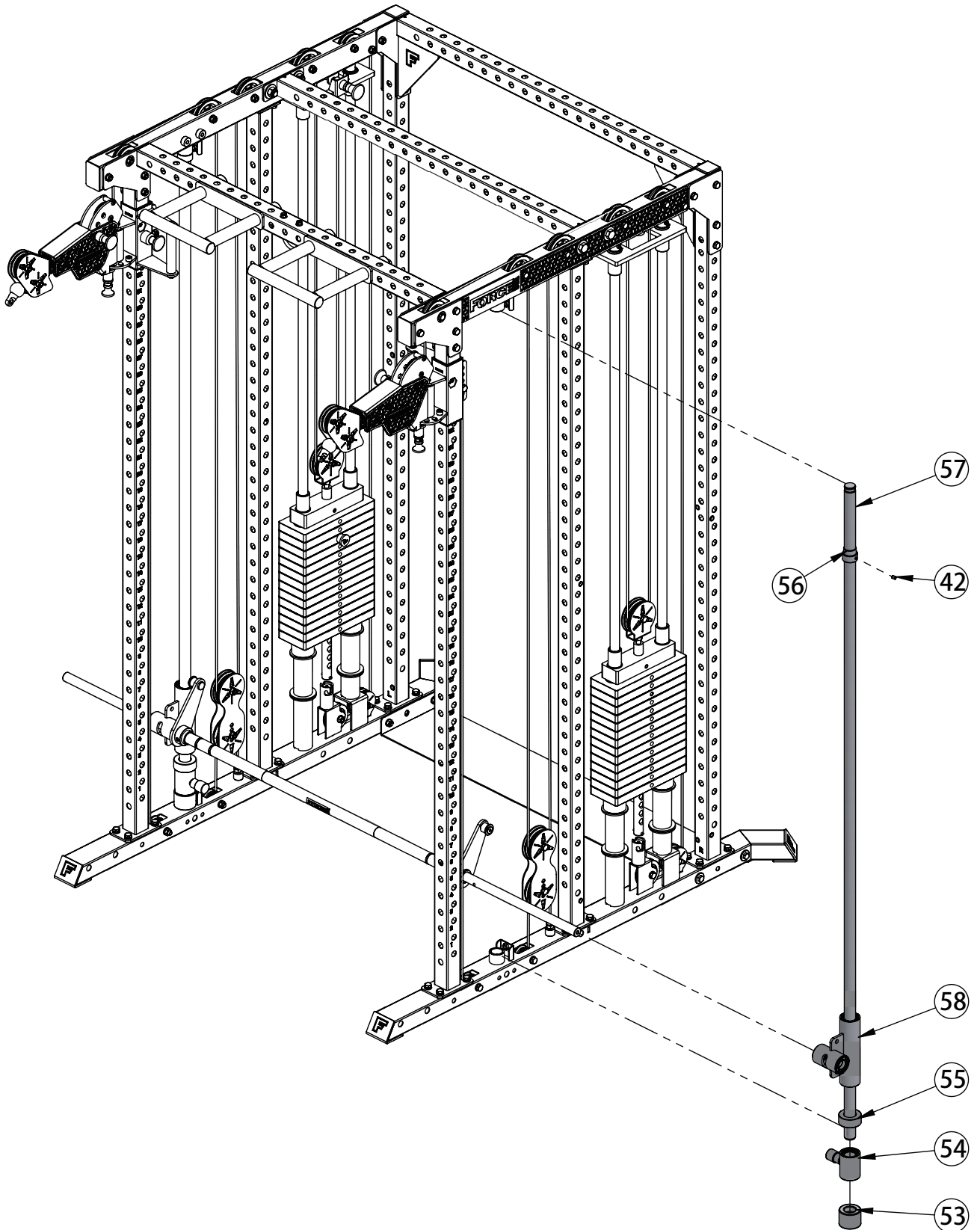

STEP15-PARTS & HARDWARE

If you haven't purchased the F-M10-SMITH, please skip this step.

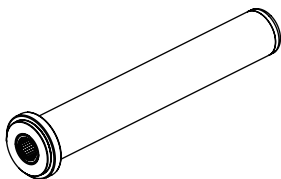

60 x2

Smith Barbell Sleeve

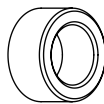

61 x2

Smith Barbell Sleeve Spacer

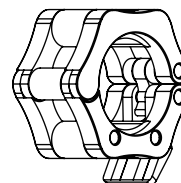

63 x2

Magnetic Olympic Lock Collar

62 x2



STEP15-ASSEMBLY



Fully tighten this step's hardware

If you haven't purchased the F-M10-SMITH, please skip this step.

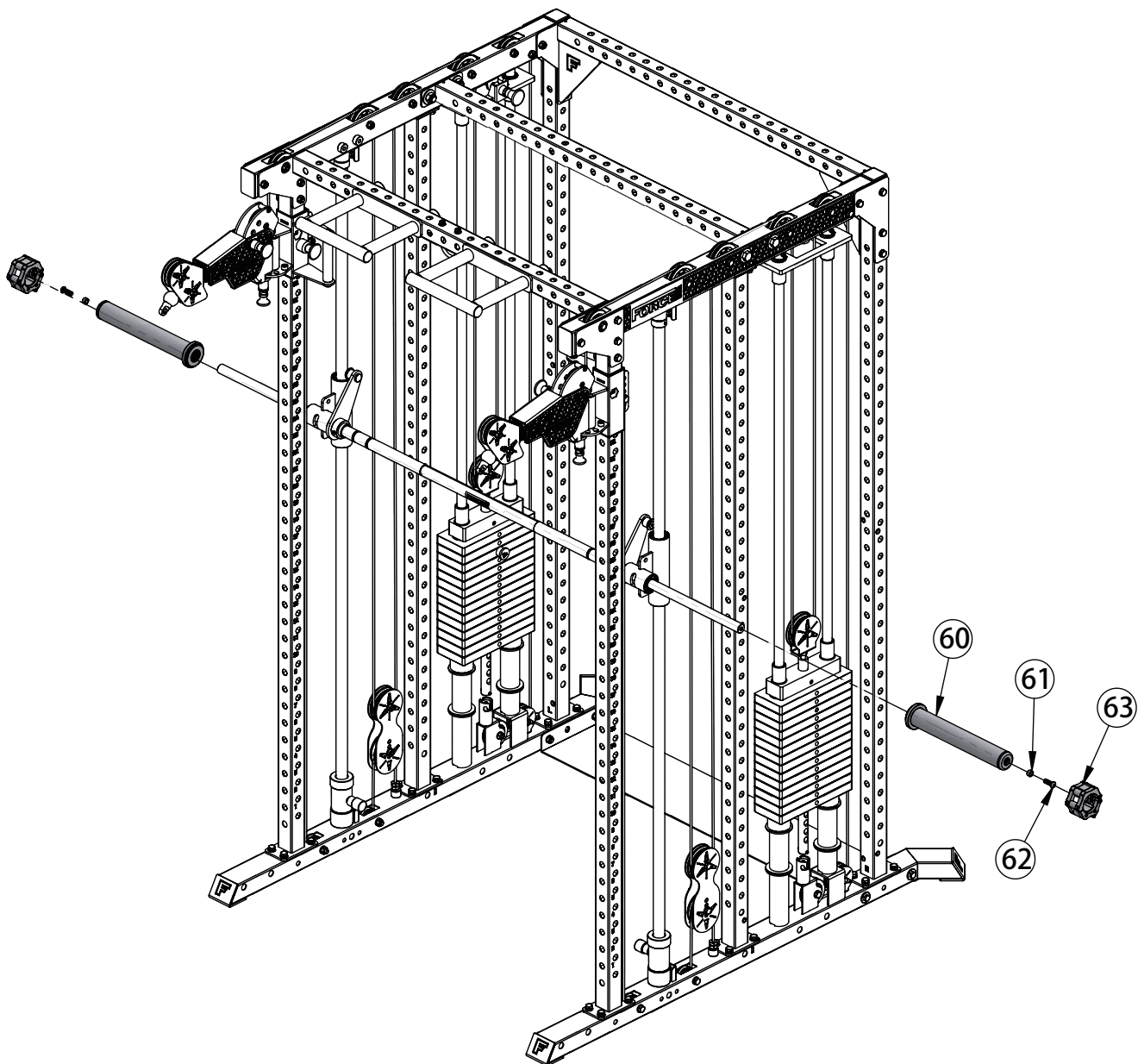

STEP16-PARTS & HARDWARE

If you haven't purchased the F-M10-SMITH, please skip this step.

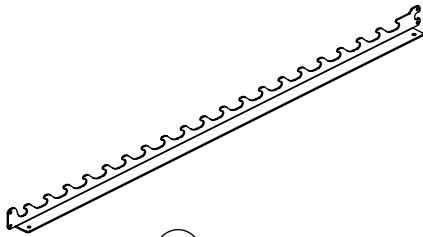

64 x1

Smith Bar Hook Plate - Right

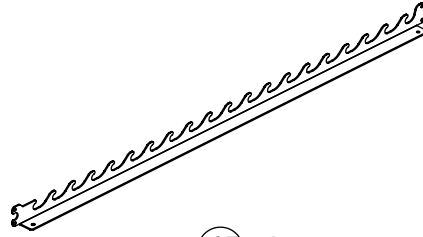

65 x1

Smith Bar Hook Plate - Left

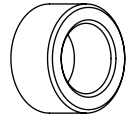

68 x2

spacer sleeve

4 x12

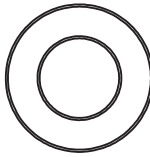

10 Flat Washer

12 x8

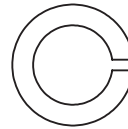

10 Spring Washer

5 x4



M10 Lock Nut

67 x8

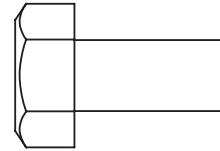

M10x20mm

3 x4

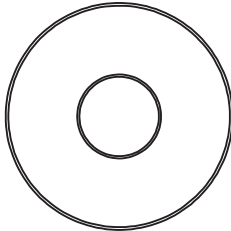

Large Flat Washer

6 x4

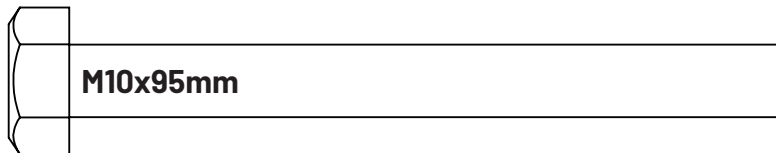

M10x95mm

66 x2

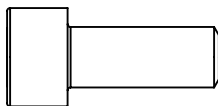

M8x20mm

STEP17-PARTS & HARDWARE

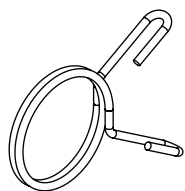

72 x8
Spring Collar

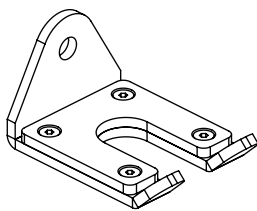

73 x1
Barbell Hanger

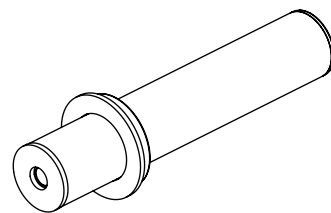

74 x8
Weight Plate Storage

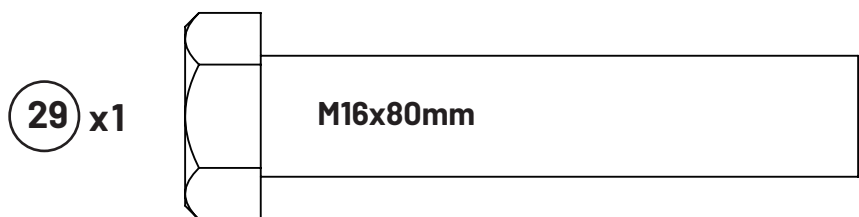

29 x1

M16x80mm

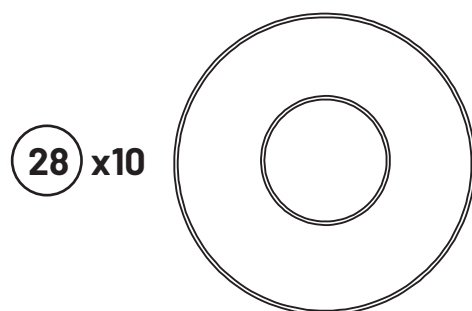

28 x10

16 Flat Washer



30 x1

M16 Lock Nut

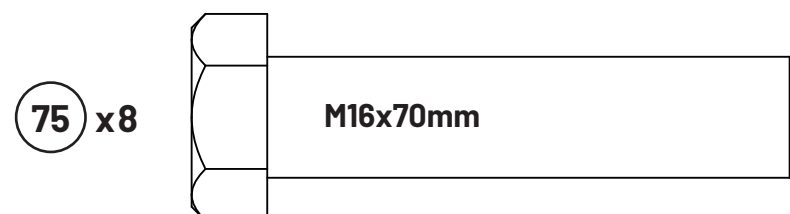

75 x8

M16x70mm

STEP17-ASSEMBLY



Fully tighten this step's hardware

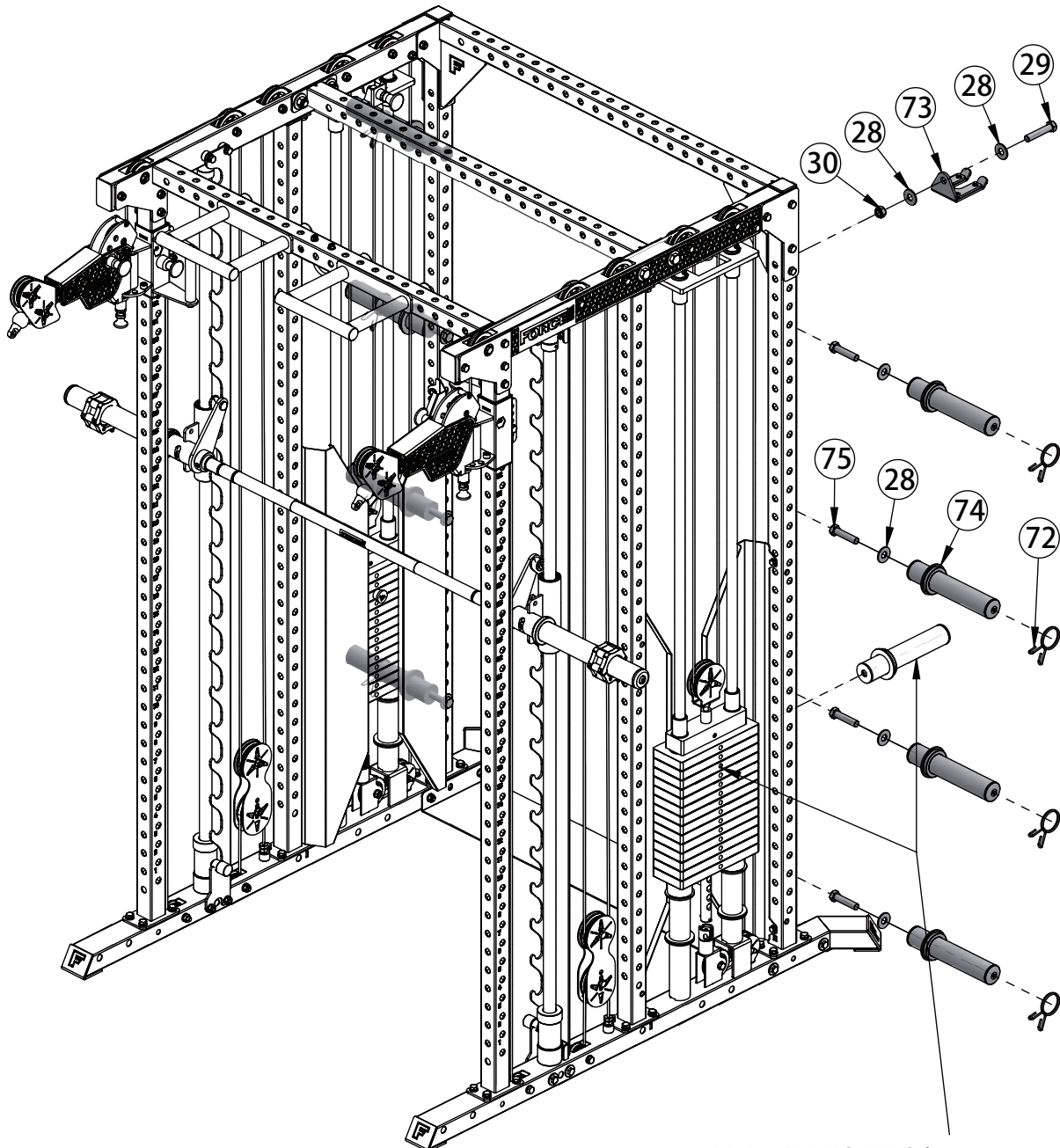

If the F-M10-PLC is selected, this parts should be installed at the back.

STEP18-PARTS & HARDWARE

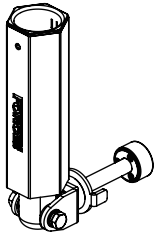

76x1
Magnetic Landmine

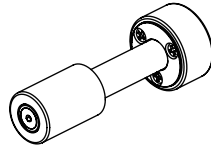

77x1
Landmine Magnet

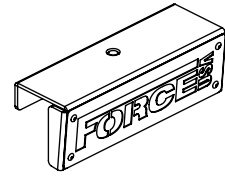

78x1
LOGO Plate

STEP18-ASSEMBLY



Fully tighten this step's hardware

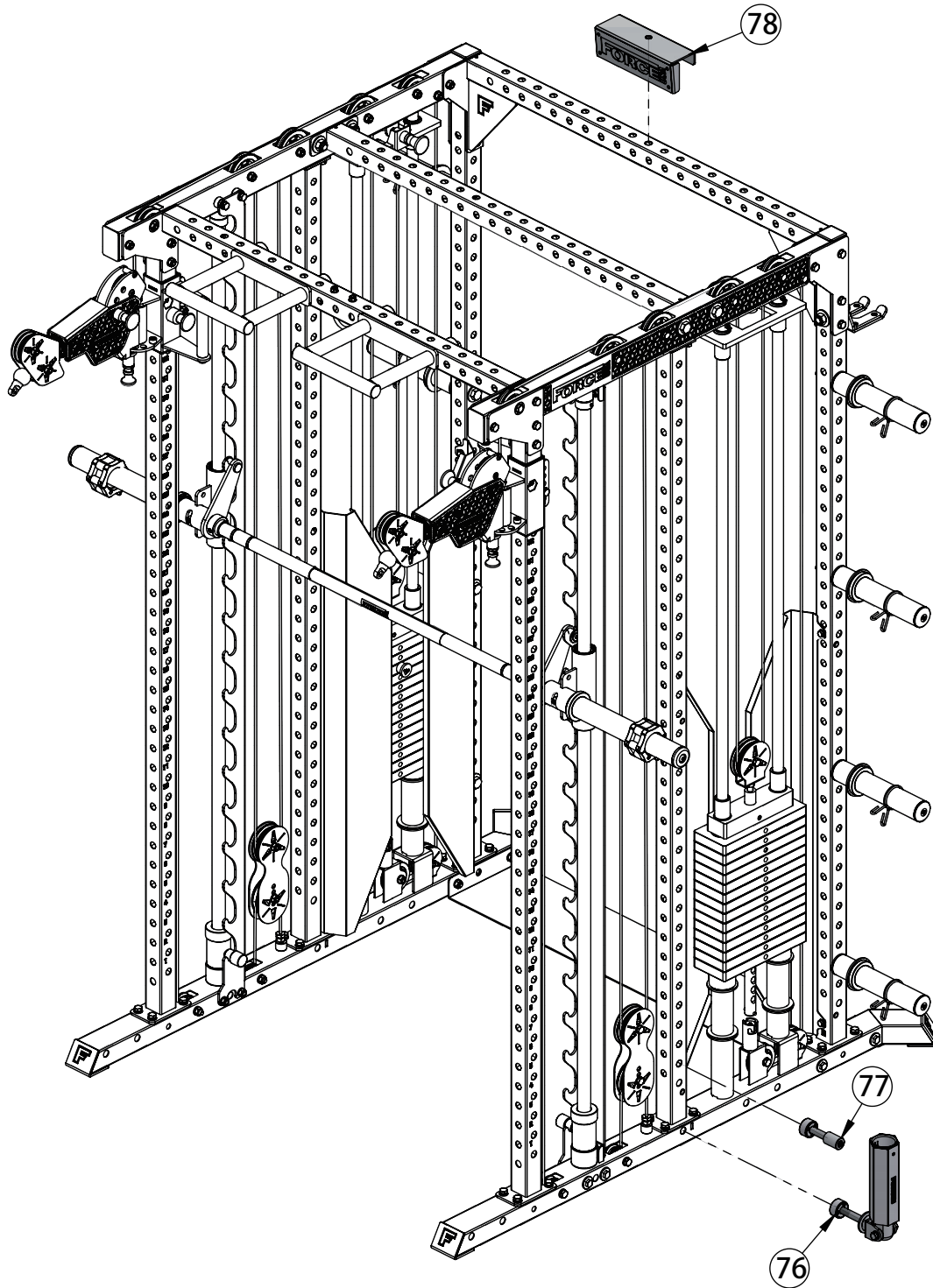

STEP19-PARTS & HARDWARE

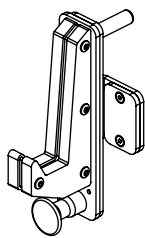

79 x1
J-Hook Right

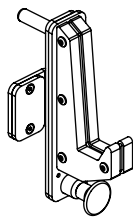

80 x1
J-Hook Left

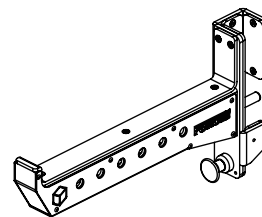

81 x1
Spotter Arm Right

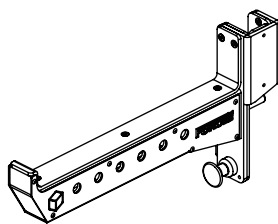

82 x1
Spotter Arm Left

STEP19-ASSEMBLY



Fully tighten this step's hardware

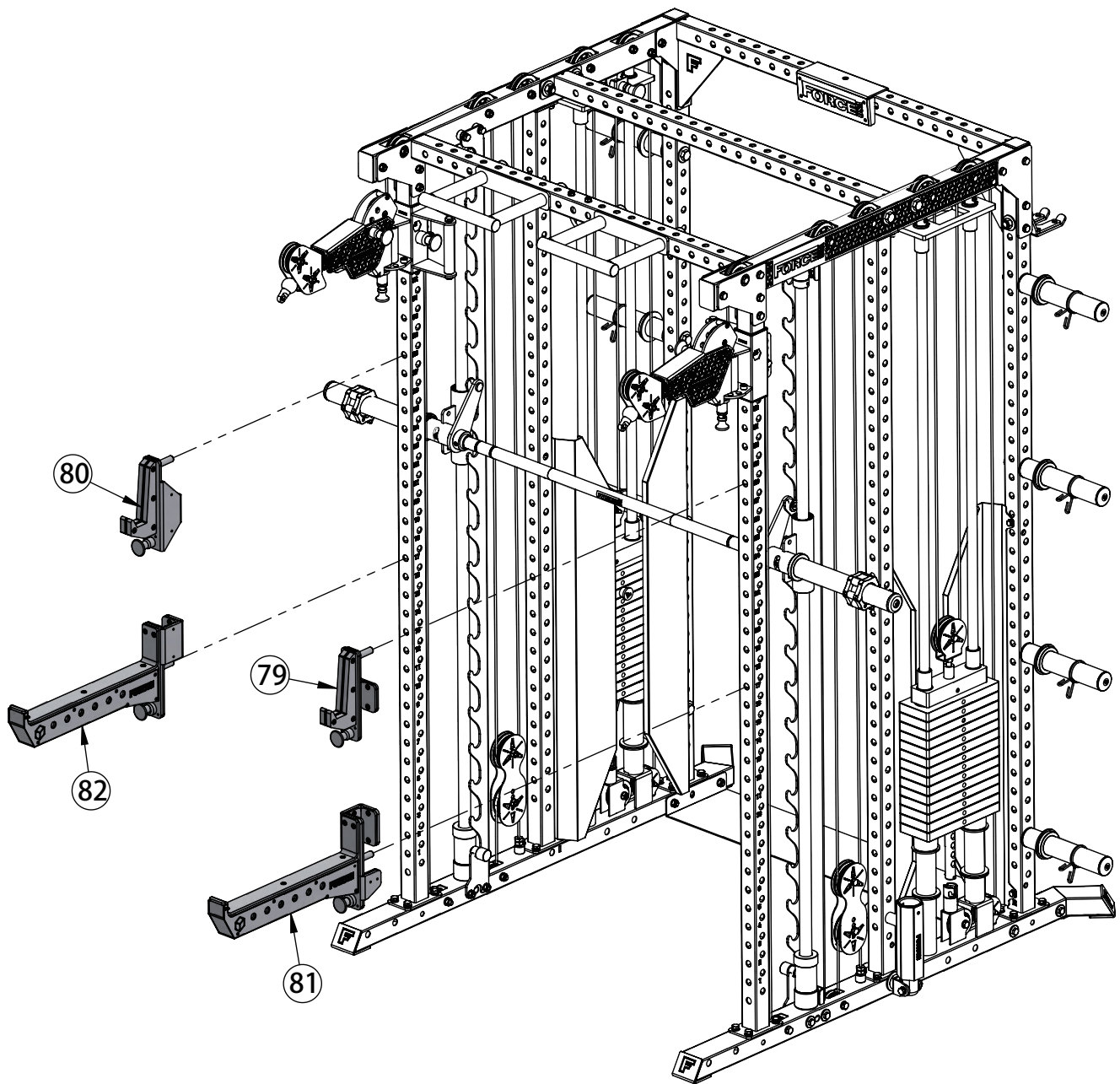

STEP20-PARTS & HARDWARE

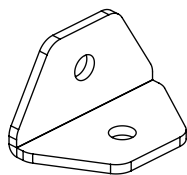

83 x4

Bracket L-Shape Floor

84 x8

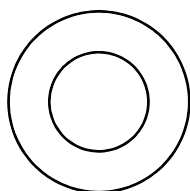

12 Flat Was

85 x4

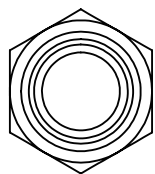

M12 Lock Nut

86 x4

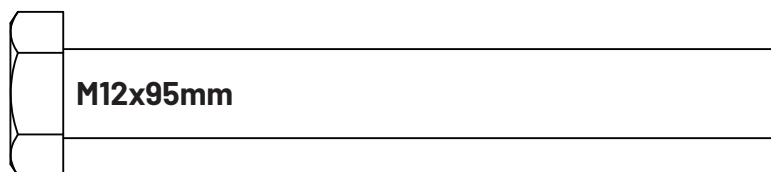

M12x95mm

STEP20-ASSEMBLY



Fully tighten this step's hardware

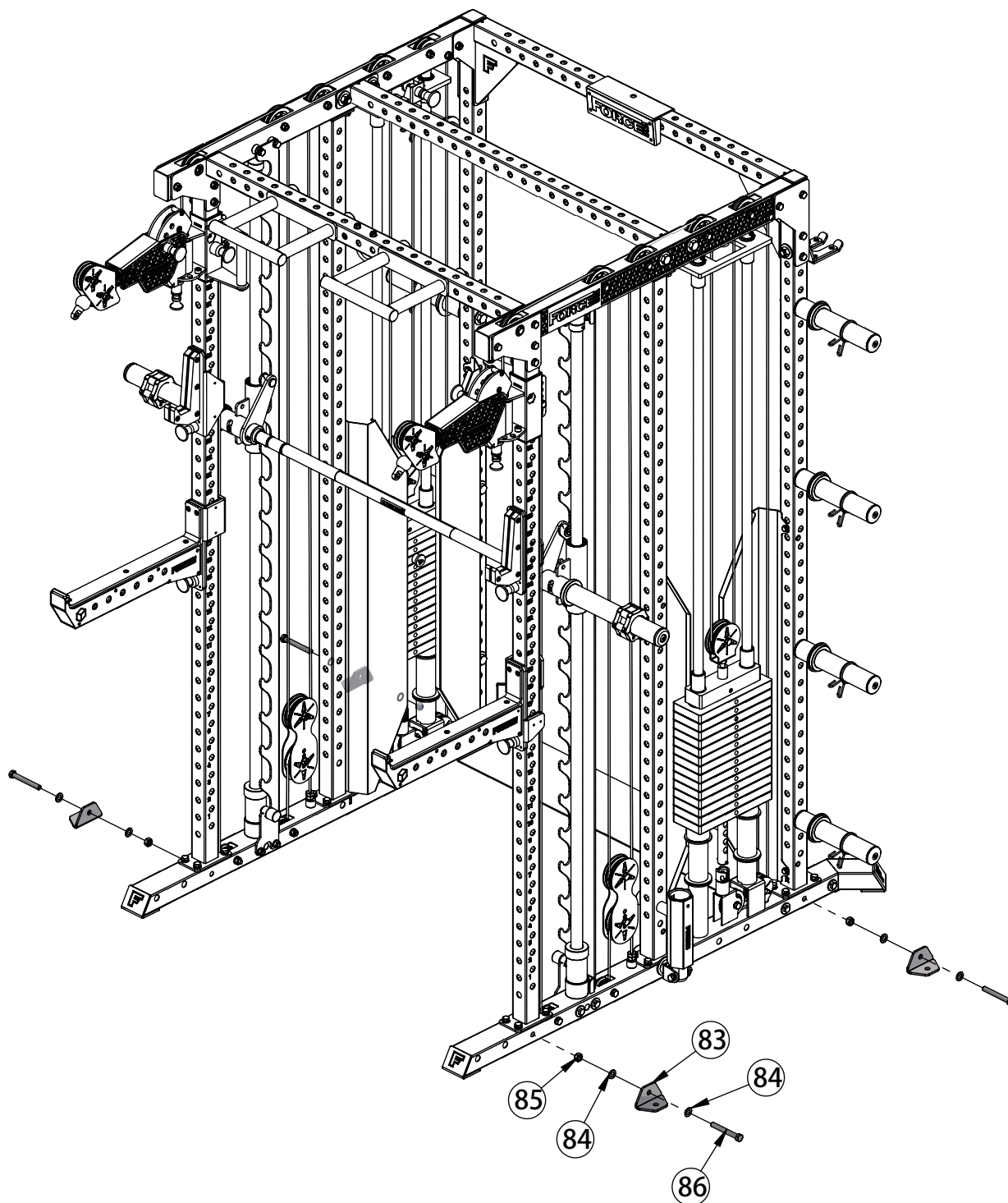

ATTACHMENTS AND ACCESSORIES

Illustrations may appear different than actual attachments



87 x1

Close Grip Triangle Landmine Handle

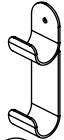

88 x2

Hook

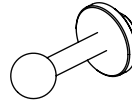

89 x4

Peg



90 x1

Ankle Cuff



91 x2

Single Knurled Handle

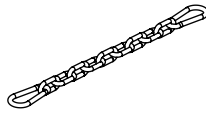

92 x4

Extension Chain



93 x1

Tricep Rope

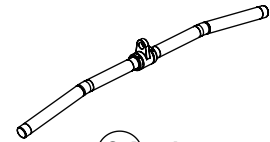

94 x1

Revolving Lat Pull Down Bar

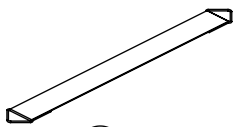

95 x1

Bodyweight Assisted Strap

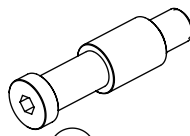

96 x8

Weight Stack Band Peg Hook

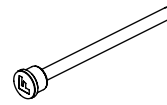

97 x4

Mag Pin

FINAL TOUCHES



Congratulations! The main unit assembly is complete. The finishing touch is to tighten all the hand tight hardware. We recommend starting at the bottom and working your way up, moving around evenly around the unit where possible. This will help ensure your unit is level and square.

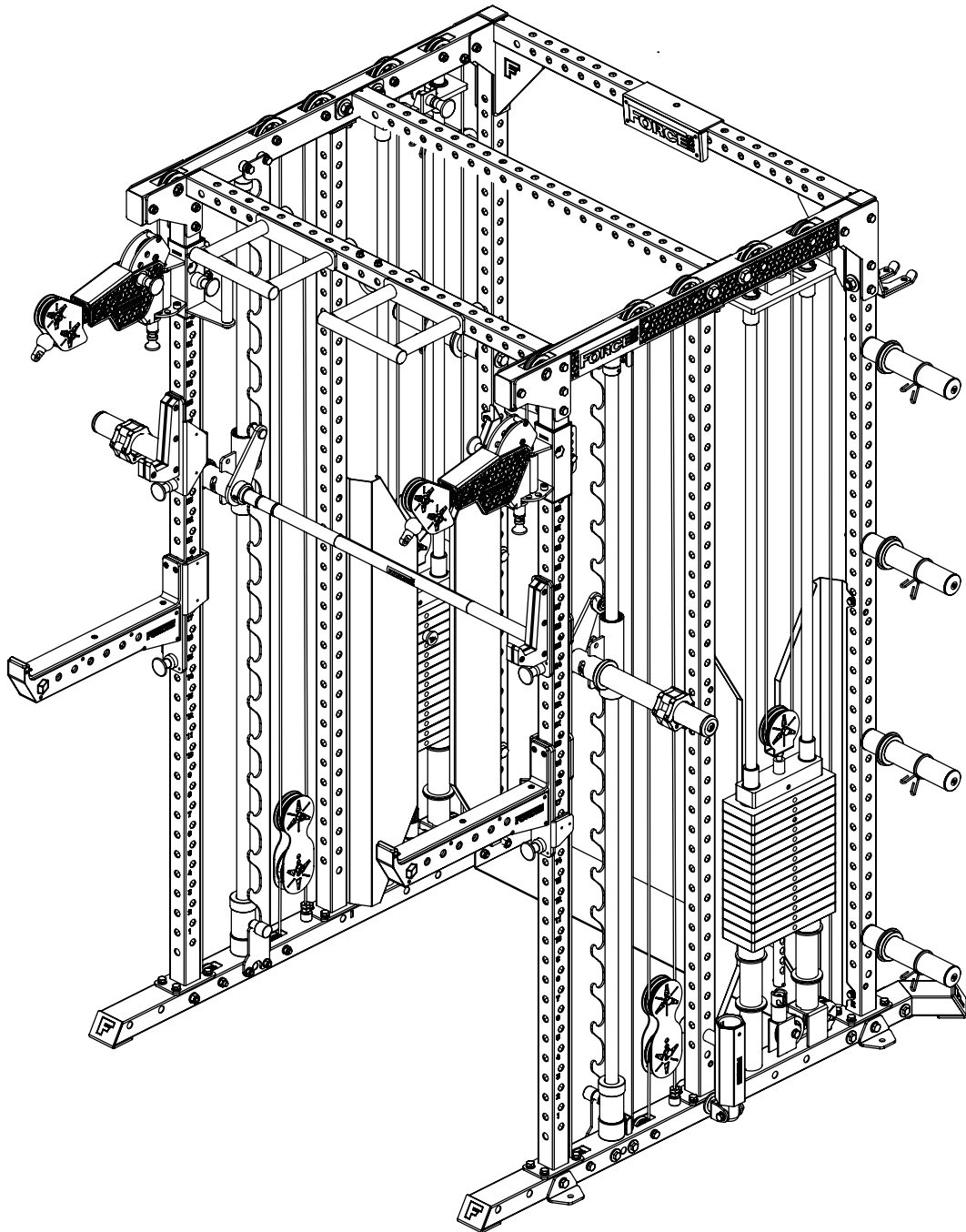

EXPLODED DIAGRAMS

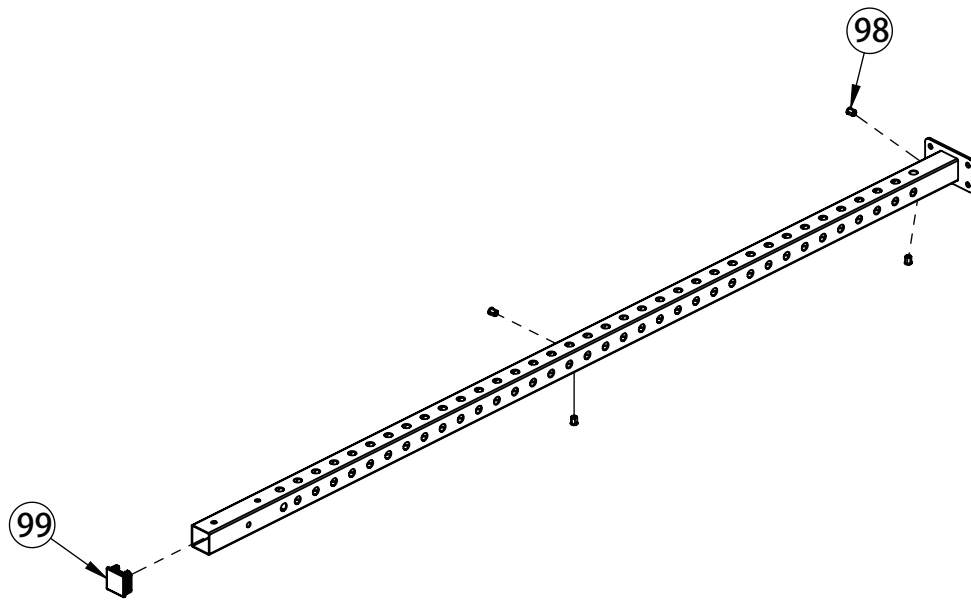

Rear Right Upright

NO.	Part Name	Specification	QTY
98	Hexagonal rivet nut	M8	4
99	Square Tube Plug	□50×50×2	1

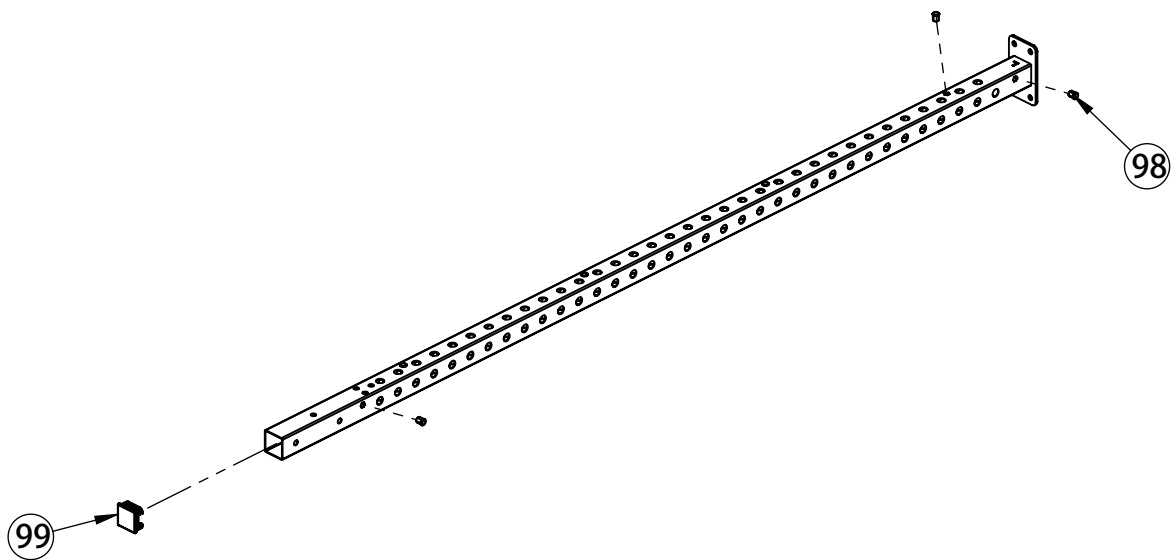

Rear Right Upright

NO.	Part Name	Specification	QTY
98	Hexagonal rivet nut	M8	4
99	Square Tube Plug	□50×50×2	1

EXPLODED DIAGRAMS

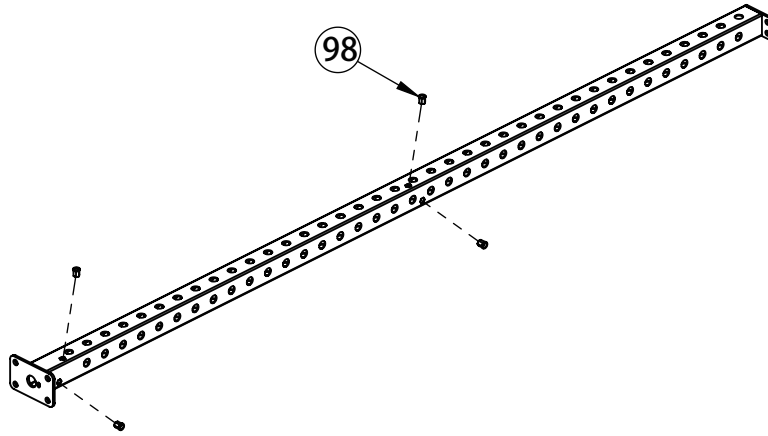

Middle Right Upright

NO.	Part Name	Specification	QTY
98	Hexagonal rivet nut	M8	4

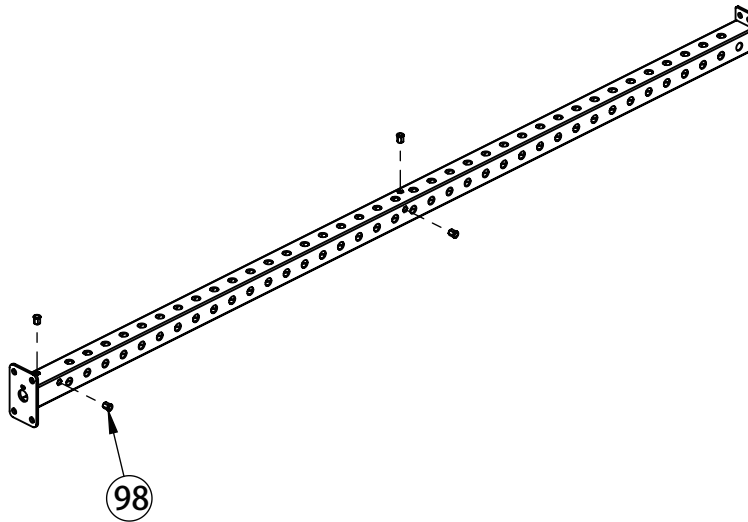

Middle Left Upright

NO.	Part Name	Specification	QTY
98	Hexagonal rivet nut	M8	4

EXPLODED DIAGRAMS

Freestyle Trolley Left

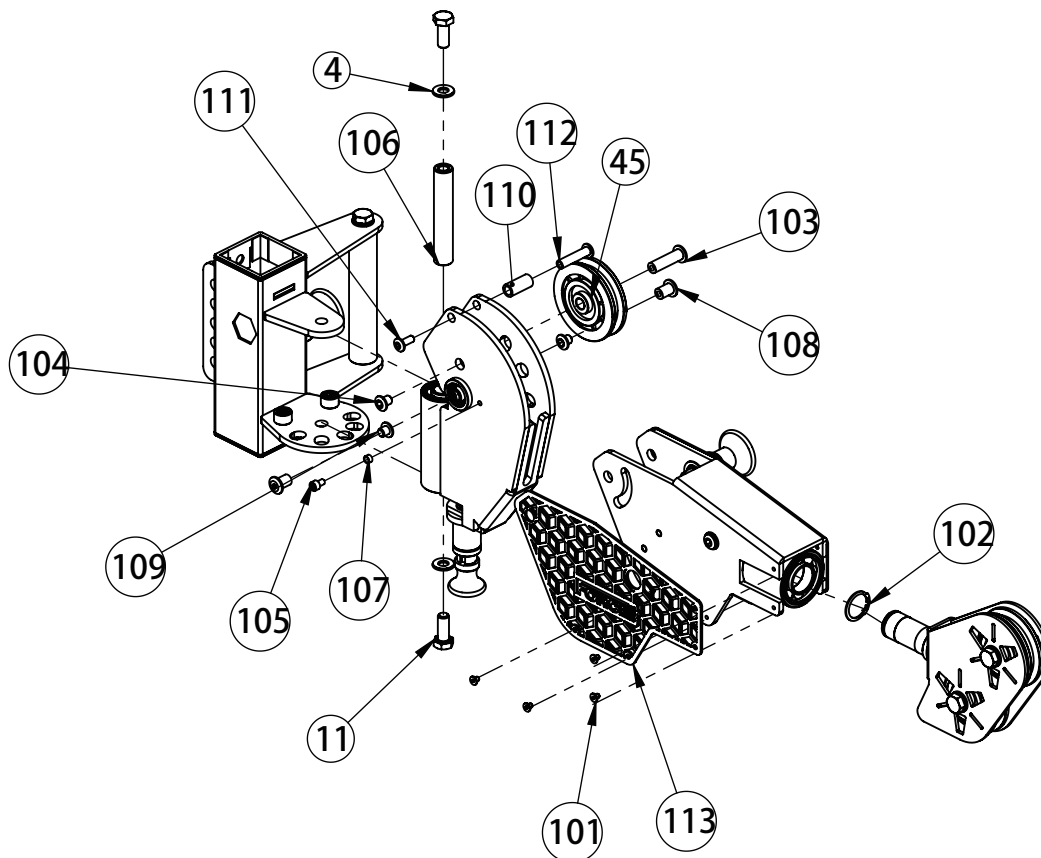

NO.	Part Name	Specification	QTY
4	M10 flat washer	M10	2
11	hexagon bolt	M10X25	2
45	M75 Pulley	M75	1
101	hexagon bolt	M4X5	4
102	elastic retaining rings	M25	1
103	hexagon bolt	M8X35	1
104	nut	M8X35	1
105	hexagon socket cap screws	M5X8	1
106	Inner shaft	M17X97	1
107	spacer sleeve	7X5.2X4	1
108	hexagon bolt	M8X16	2
109	nut	M8X16	2
110	drivepipe	M12XM8.1X26	1
111	hexagon bolt	M6X35	1
112	nut	M6X35	1
113	LOGO plate		1

EXPLODED DIAGRAMS

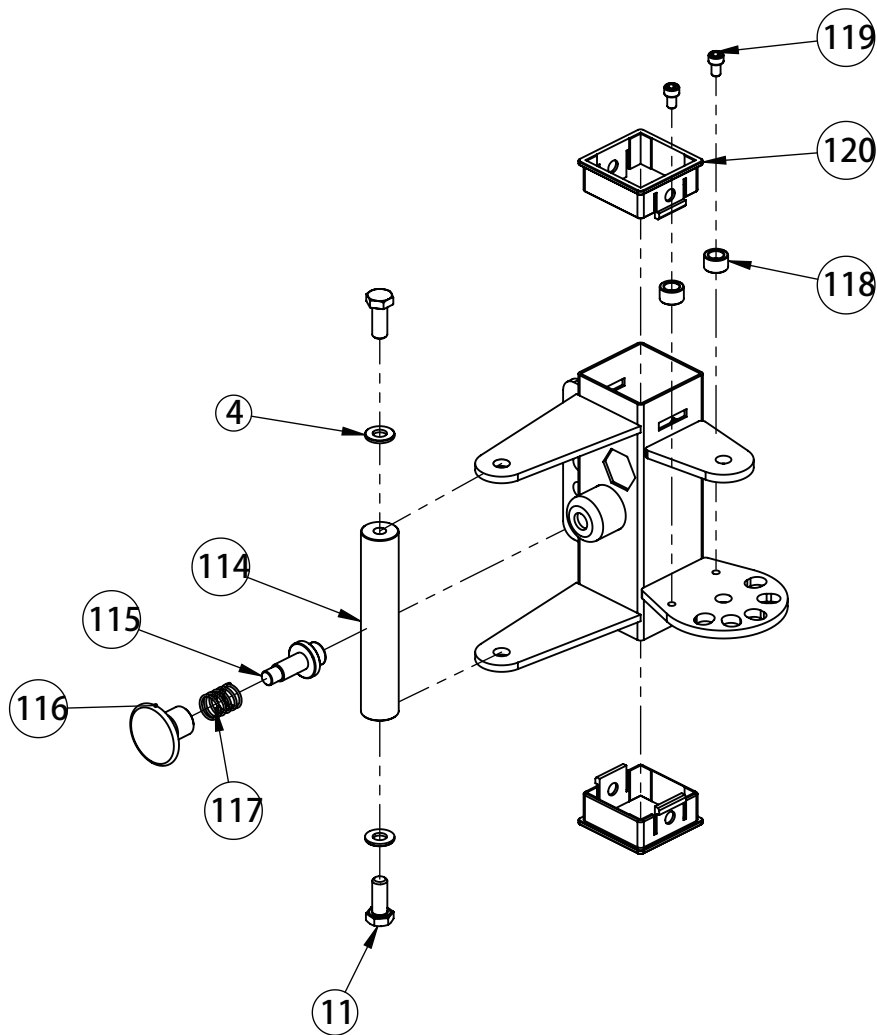

NO.	Part Name	Specification	QTY
4	M10 flat washer	M10	2
11	hexagon bolt	M10X25	2
114	handle	M25X138	1
115	Pulling pin shaft	M25	1
116	Pulling handle	M44	1
117	Pulling spring		1
118	Impact protection sleeve	M16	2
119	hexagon socket cap screws	M6X10	2
120	Bushing	50-60	2

EXPLODED DIAGRAMS

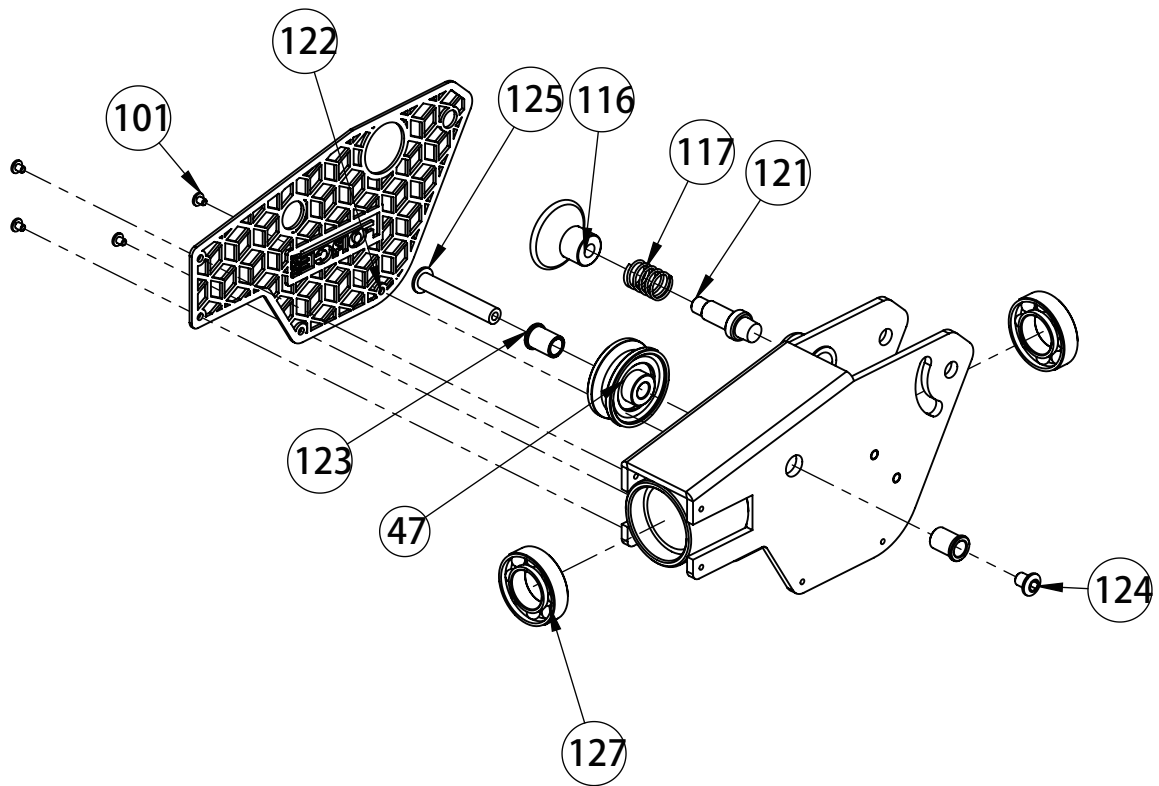

NO.	Part Name	Specification	QTY
47	M50 pulley	M50	1
101	Flat head hexagonal screw	M4X5	4
116	Pulling handle	M44	1
117	Pulling spring		1
121	Pulling pin shaft	M18	1
122	LOGO plate		1
123	Spacer sleeve	M16	2
124	hexagon bolt	M8x60	1
125	Nut	M8x60	1
126	plastic mat		4
127	deep groove ball bearing	6005	2

EXPLODED DIAGRAMS

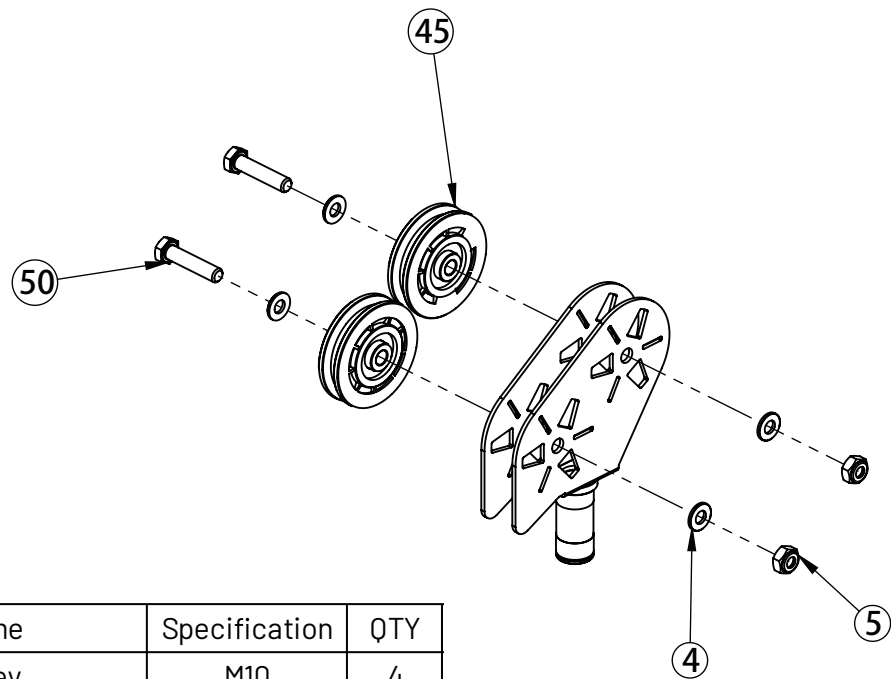

NO.	Part Name	Specification	QTY
4	M50 pulley	M10	4
5	nut	M10	2
45	M75 pulley	M75	2
50	hexagon bolt	M10X45	2

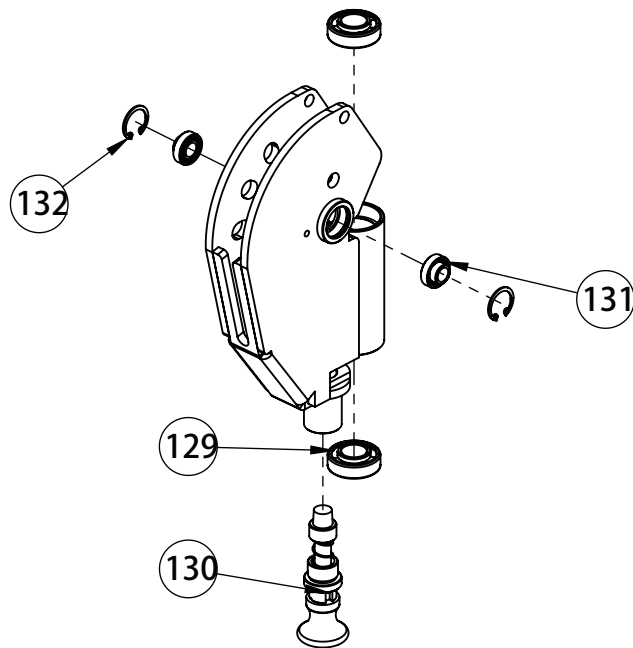

NO.	Part Name	Specification	QTY
129	deep groove ball bearing	6003	2
130	Positioning pull tab		1
131	deep groove ball bearing	31900	2
132	circlip for hole	M22	2

EXPLODED DIAGRAMS

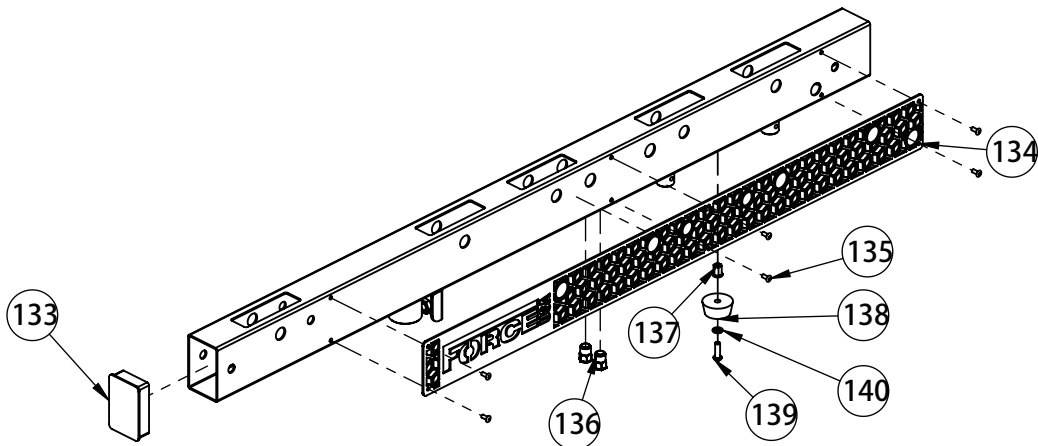

NO.	Part Name	Specification	QTY
133	Square Tube Plug	50X75X2	1
134	LOGO plate		1
135	blind rivet	4x10	6
136	Screw-on hexagonal rivet nut	M10	2
137	Hexagonal rivet nut	M6	1
138	Conical buffer pad		1
139	Hex socket flat head screw	M6X20	1
140	flat washer	M6	1

Right Top Frame

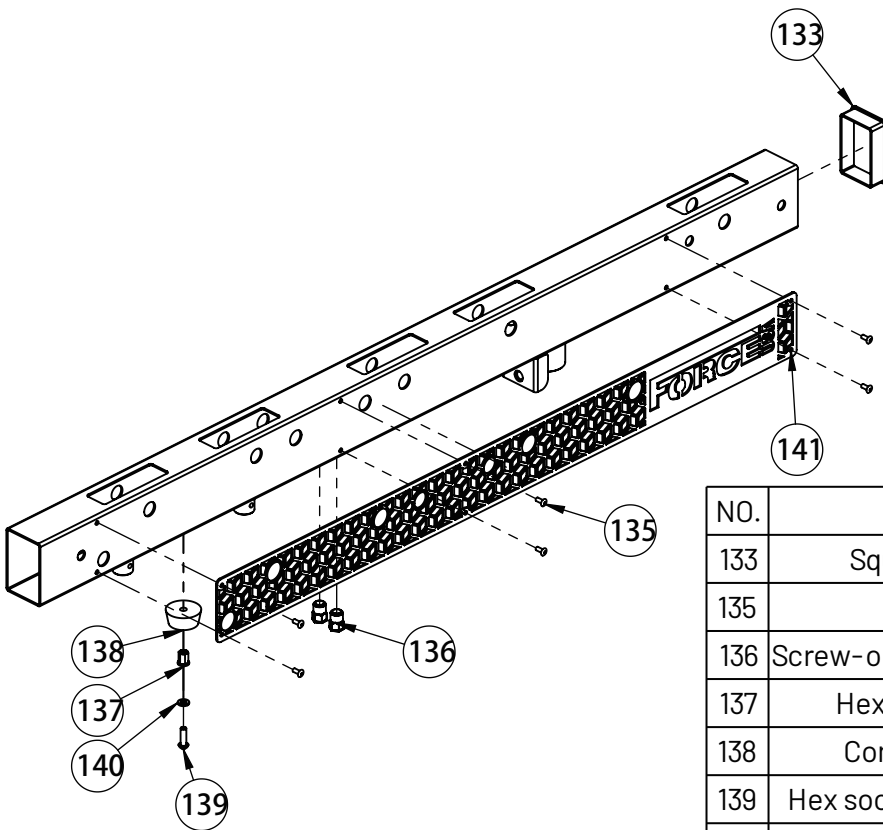

NO.	Part Name	Specification	QTY
133	Square Tube Plug	50X75X2	1
135	blind rivet	4x10	6
136	Screw-on hexagonal rivet nut	M10	2
137	Hexagonal rivet nut	M6	1
138	Conical buffer pad		1
139	Hex socket flat head screw	M6X20	1
140	flat washer	M6	1
141	LOGO plate		1

Left Top Frame

EXPLODED DIAGRAMS

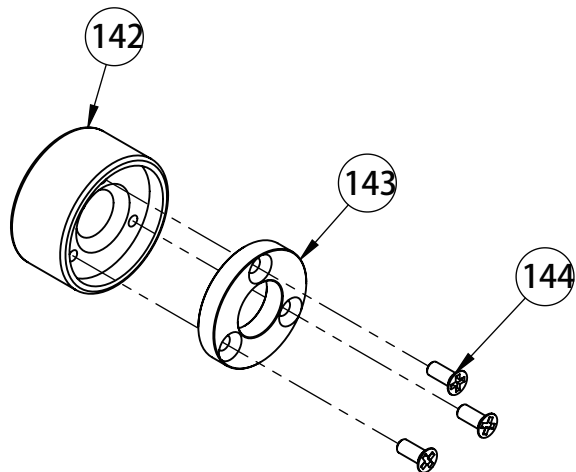

NO.	Part Name	Specification	QTY
142	nut	M40	1
143	rubber mat		1
144	Cross-slot small countersunk screw	M4X10	3

Knurled Nut

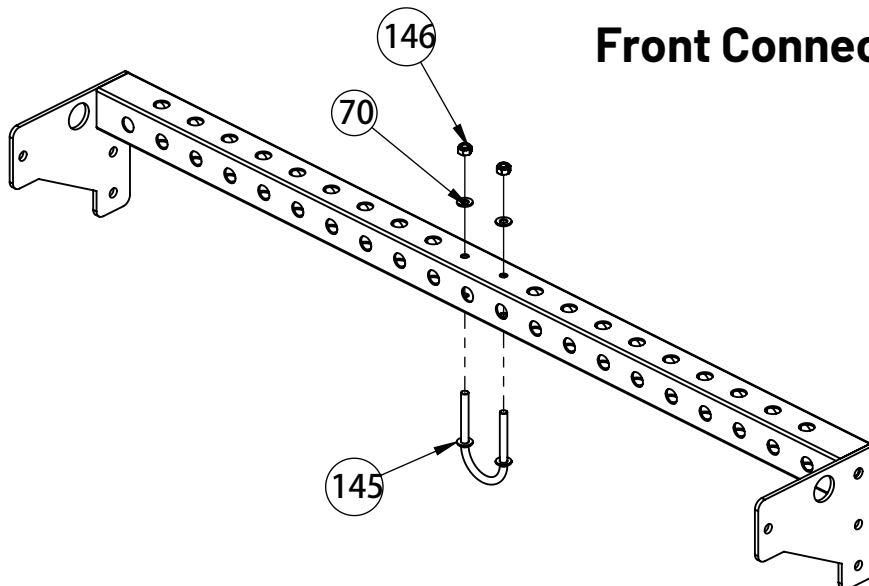

Front Connection Frame

NO.	Part Name	Specification	QTY
70	flat washer	M8	2
145	hanging ring		1
146	Nut	M8	2

EXPLODED DIAGRAMS

2KG Incremental Weight Plate

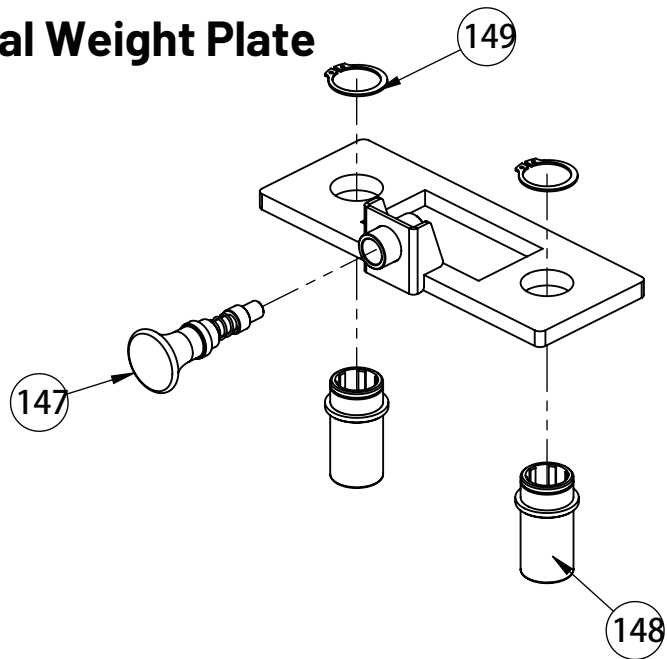

NO.	Part Name	Specification	QTY
147	Handle release pin of umbrella	M12XM20X40	1
148	plastic sleeve		2
149	elastic collar	35	2

Pulley Frame

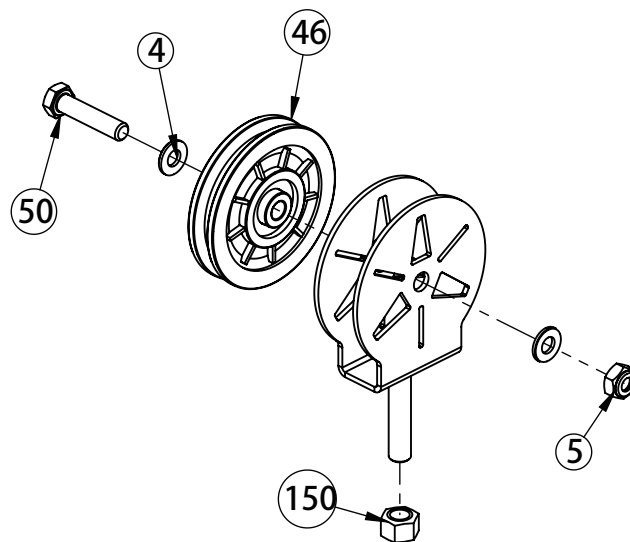

NO.	Part Name	Specification	QTY
4	flat washer	M10	2
5	nut	M10	1
46	90 pulley		1
50	hexagon bolt	M10X45	1
150	nut	M12	1

EXPLODED DIAGRAMS

Weight Plate Frame

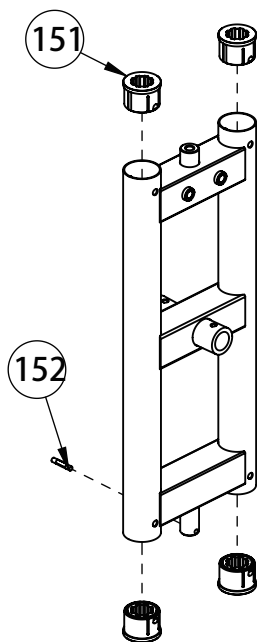

NO.	Part Name	Specification	QTY
151	plastic sleeve		4
152	plug		1

Weight Plate Storage

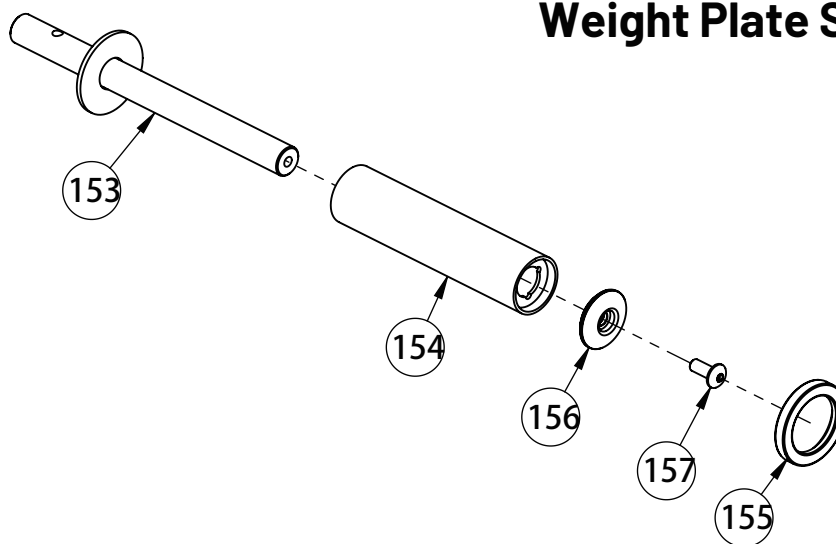

NO.	Part Name	Specification	QTY
153	Barbell holder		1
154	Barbell tube		1
155	Rubber retaining ring		1
156	Decorative aluminum cover		1
157	hexagon blot	M10X25	1

EXPLODED DIAGRAMS

Pulley Bracket

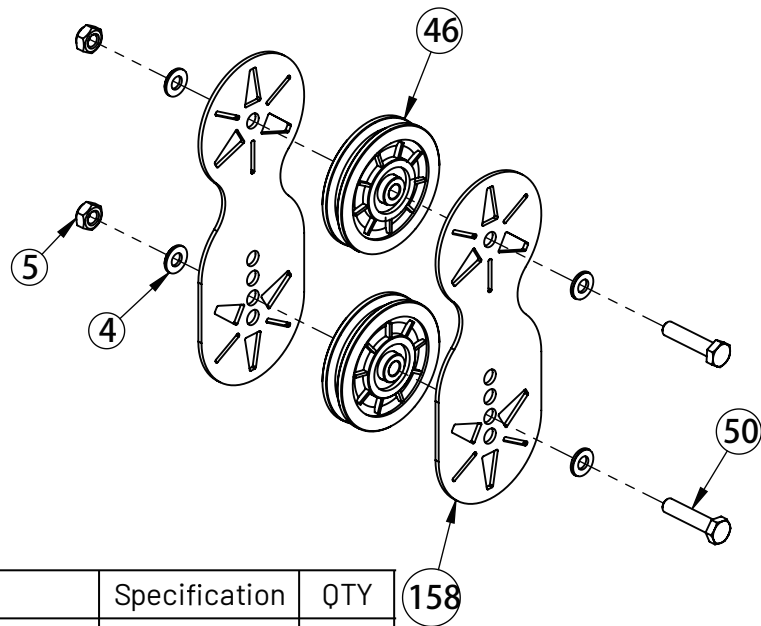

NO.	Part Name	Specification	QTY
4	flat washer	M10	4
5	nut	M10	2
46	90 pulley		2
50	hexagon blot	M10X45	2
158	Pulley adjustment plate		2

Smith Bar Safety Hook

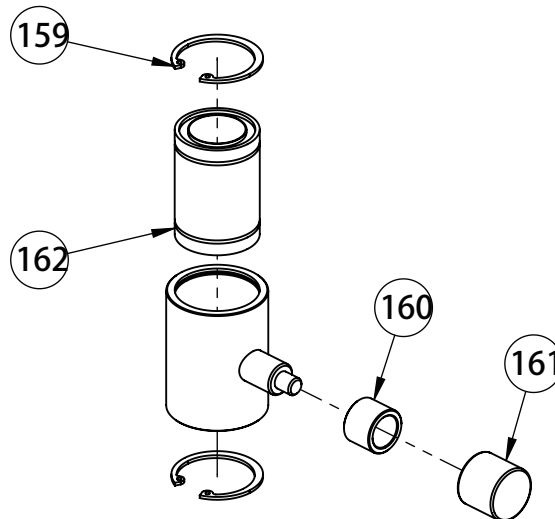

NO.	Part Name	Specification	QTY
159	elastic collar	45	2
160	Safety interval sleeve		1
161	Safety handle		1
162	linear bearing		1

EXPLODED DIAGRAMS

Smith Bar Sliding Frame

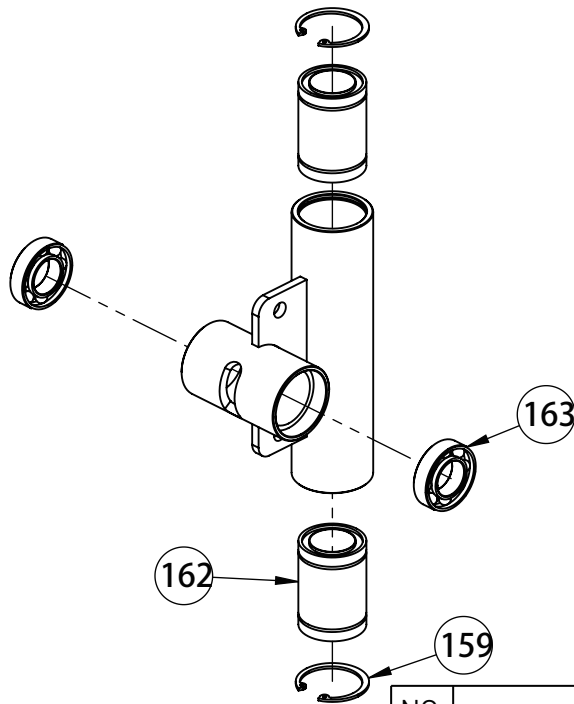

NO.	Part Name	Specification	QTY
159	elastic collar	45	2
162	linear bearing		2
163	deep groove ball bearing		2

Smith Bar

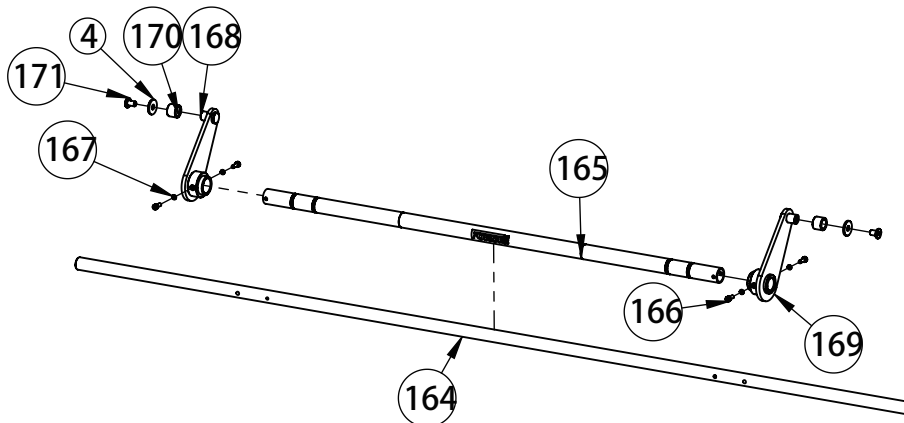

NO.	Part Name	Specification	QTY
4	flat washer	M30XM10X3	2
164	Barbell inner bar		1
165	Barbell aluminum bar		1
166	hexagon bolt	M6X16	4
167	spring washer	M6X16	4
168	Left hook		1
169	Right hook		1
170	Safety interval sleeve		2
171	hexagon bolt	M10X16	2

EXPLODED DIAGRAMS

Smith Barbell Sleeve

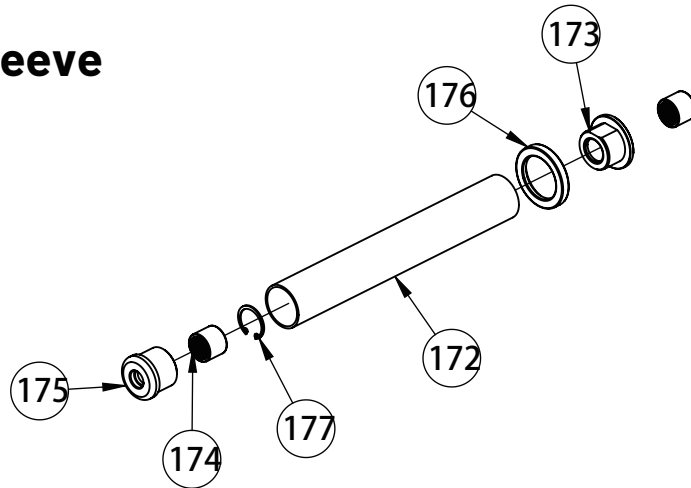

NO.	Part Name	Specification	QTY
172	Barbell sleeve		1
173	Aluminum inner retaining ring	M60	1
174	needle roller bearing		2
175	barbell bar end cap		1
176	Rubber retaining ring		1
177	elastic collar		1

Barbell Hanger

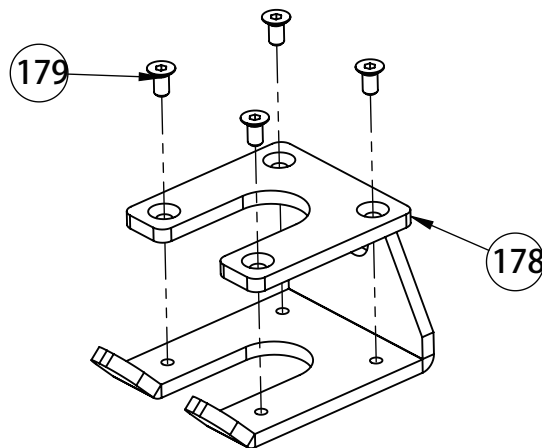

NO.	Part Name	Specification	QTY
178	Hooked gasket		1
179	hexagon bolt	M6X12	4

EXPLODED DIAGRAMS

Weight Plate Storage

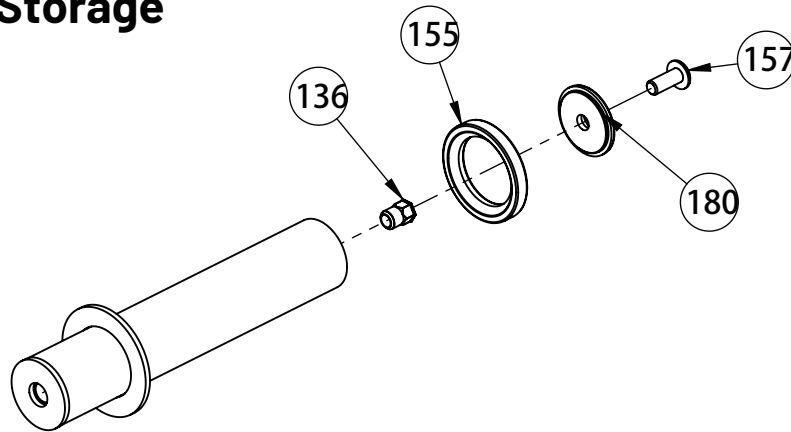

NO.	Part Name	Specification	QTY
136	Screw-on hexagonal rivet nut	M10	1
155	Rubber retaining ring		1
157	hexagon bolt	M10X25	1
180	Decorative aluminum cover		1

Landmine Magnet

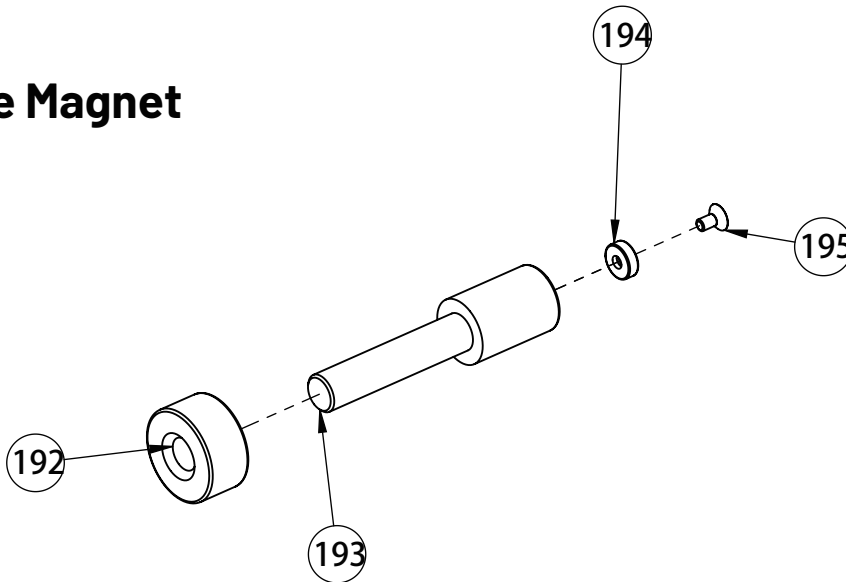

NO.	Part Name	Specification	QTY
192	nut		1
193	Magnetic coupling shaft	M28	1
194	strong magnet		1
195	hexagon bolt	M5X10	1

EXPLODED DIAGRAMS

J-Hook Right And Left

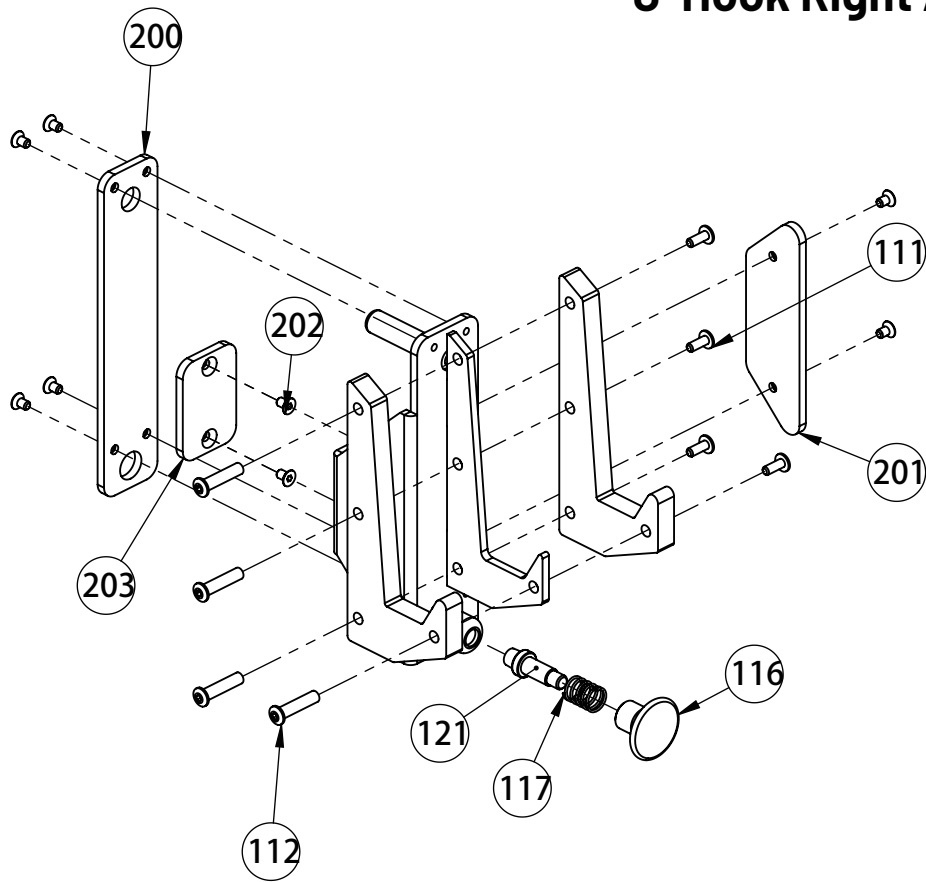

NO.	Part Name	Specification	QTY
111	hexagon bolt	M6X35	4
112	nut	M6X35	4
116	Pulling handle		1
117	Pulling spring	M5X10	1
121	Pulling pin shaft		1
197	Hook plate		2
200	Long rubber sheet		1
201	Laminated rubber sheet		1
202	hexagon bolt	M6X16	8
203	Short spacer plate		1

EXPLODED DIAGRAMS

Magnetic Landmine

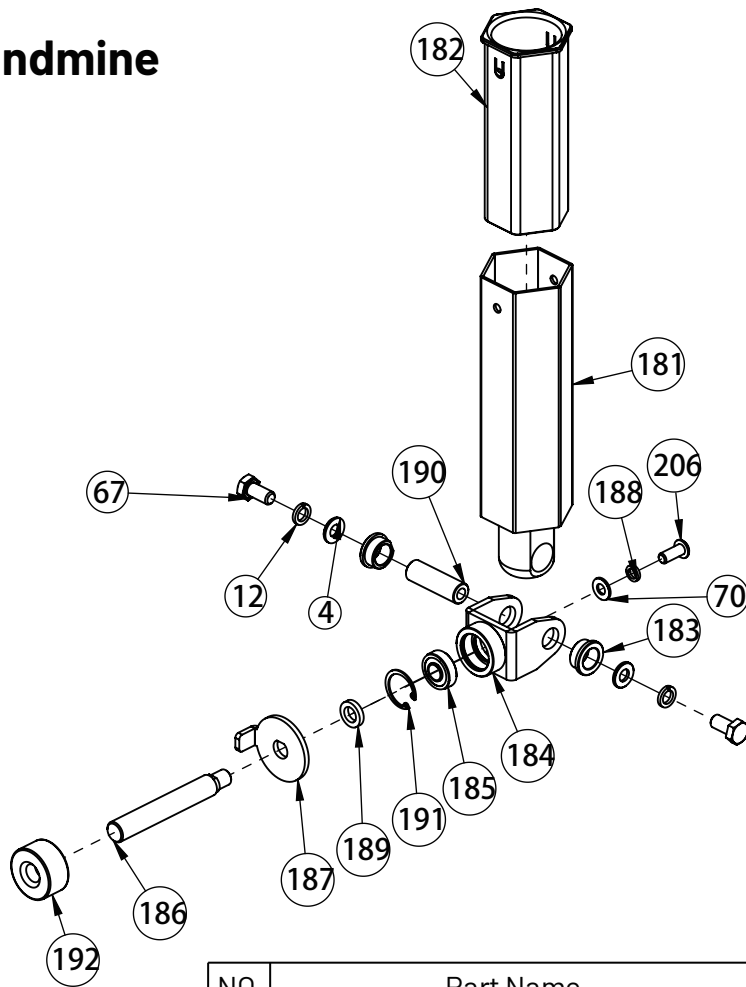

NO.	Part Name	Specification	QTY
4	flat washer	M10	2
12	spring washer	M10	2
206	hexagon bolt	M8X20	1
67	hexagon bolt	M10X20	2
70	flat washer	M8	1
181	Landmine		1
182	reduction sleeve		1
183	Powder sleeve		2
184	Universal U-shaped part	M6X16	1
185	deep groove ball bearing	6001	1
186	universal joint	M25	1
187	Universal gasket		1
188	spring washer		1
189	Universal gasket	M8	1
190	Inner shaft	M15.8	1
191	elastic collar		1
192	nut	M16	1

EXPLODED DIAGRAMS

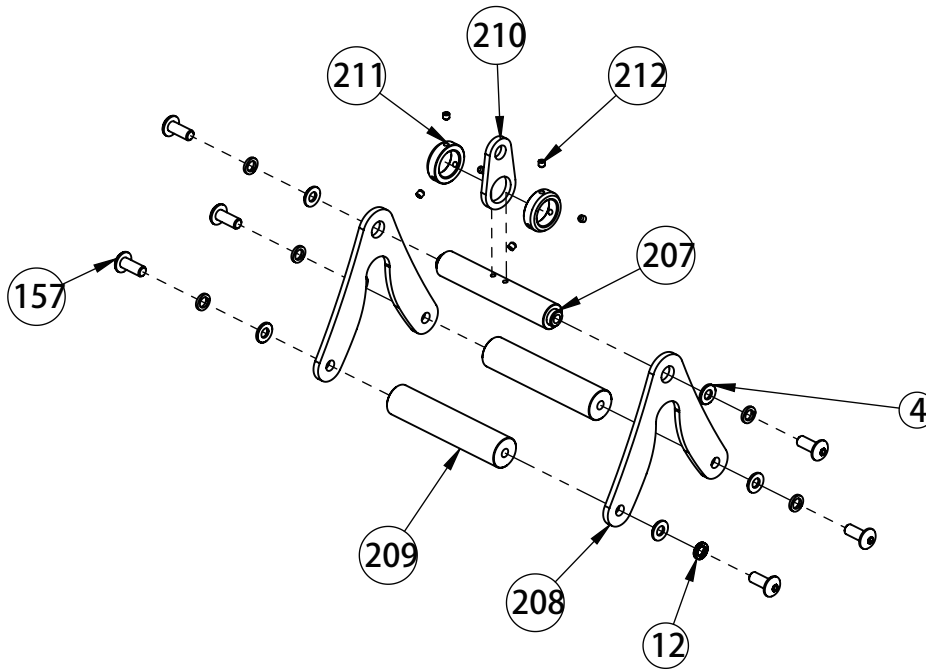

Close Grip Triangular Landmine Handle

NO.	Part Name	Specification	QTY
4	flat washer	M10	6
12	spring washer	M10	7
157	hexagon bolt	M10x25	6
207	Traction shaft		1
208	Pull the handle plate		2
209	Pull the handle shaft		2
210	Large hook plate		1
211	large puller handle retaining ring		2
212	hexagon bolt	M6X6	6

EXPLODED DIAGRAMS

Spotter Arm Right

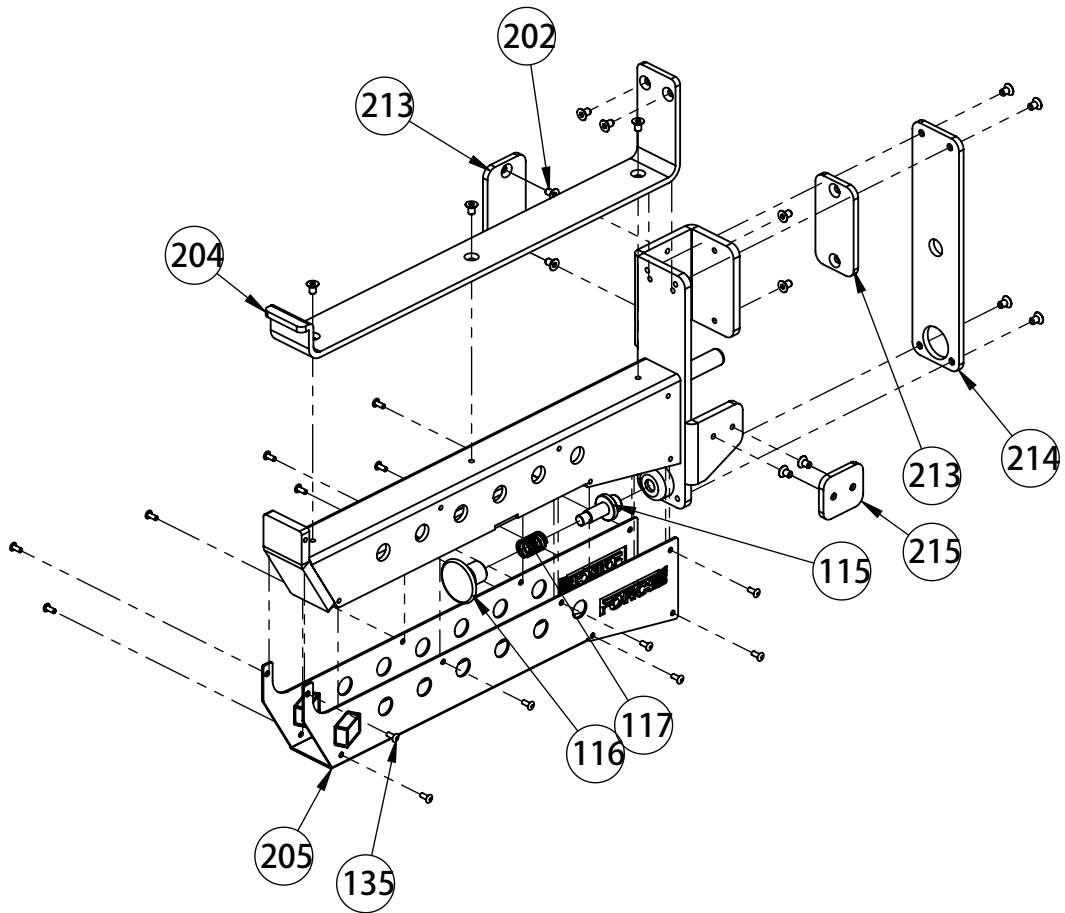

NO.	Part Name	Specification	QTY
115	Pulling pin shaft	M25	1
116	Pulling handle	M44	1
117	Pulling spring		1
135	blind rivet	4X10	15
202	hexagon bolt	M6X10	15
204	rubber mat		1
205	Decorative plate		1
213	Short spacer plate		2
214	Long rubber sheet		1
215	Short spacer plate		1

EXPLODED DIAGRAMS

LOGO Plate

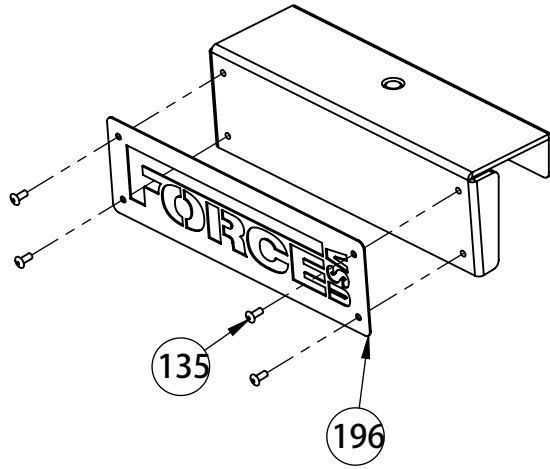

NO.	Part Name	Specification	QTY
135	blind rivet	4X10	4
196	LOGO plate	M44	1

PART LIST

NO.	Part Name	Specification	QTY
1	Base Frame - Right		1
2	Connection Frame		1
3	Flat washer	M30XM10X3	12
4	Flat washer	M10	122
5	Nut	M10	54
6	Lock Nut	M10	12
7	Base Frame - Left		1
8	Rear Top Connecting Frame		1
9	Rear Top Support Bracket		2
10	Hexagon Bolt	M10x75	16
11	Hexagon Bolt	M10x25	34
12	Sping Washer	M10	45
13	Rear Right Upright		1
14	Rear Left Upright		1
15	Hexagon Bolt	M10x70	2
16	Front Upright		2
17	Middle Right Upright		1
18	Middle Left Upright		1
19	Freestyle Trolley Right		1
20	Freestyle Trolley Left		1
21	Right Top Frame		1
22	Left Top Frame		1
23	Adjustable Pull Up Handle		2
24	Knurled Nut		4
25	Front Top Support Bracket		2
26	Front Connection Frame		1
27	Middle Connection Frame		1
28	flat washer	M17XM40X3	18
29	Hexagon Bolt	M16X80	5
30	Nut	M16	5
31	Guide Rod		4
32	Weight Stack Rubber Bumper		4
33	Weight Stack Spacer		4
34	Weight Stack		2

PART LIST

NO.	Part Name	Specification	QTY
35	2KG Incremental Weight Plate		2
36	Pulley Frame		2
37	Weight Stack Selector Pin		2
38	Hexagon Bolt	M6X10	4
39	Weight Plate Frame		2
40	Weight Plate Storage		4
41	Spring Collar		4
42	Hexagon Bolt	M8X10	6
43	Upper Main Frame Cable		2
44	Pulley Bracket		2
45	75mm Pulley		14
46	90mm Pulley		12
47	50mm Pulley		8
48	Pulley Bushing		24
49	Hexagon Bolt	M10X65	12
50	Hexagon Bolt	M10X45	14
51	Lower Main Frame Cable		2
52	Pulley Bushing		8
53	Smith Bar Guide RodBottom Insert		2
54	Smith Bar Safety Hook		2
55	Smith Bar Rubber Bumper		2
56	Smith Bar Top Locking Sleeve		2
57	Smith Bar Guide Rod		2
58	Smith Bar Sliding Frame		2
59	Smith Bar		1
60	Smith Barbell Sleeve		2
61	Smith Barbell Sleeve Spacer		2
62	Hexagon Bolt	M10X30	2
63	Magnetic Olympic Lock Collar		2
64	Smith Bar Hook Plate - Right		1
65	Smith Bar Hook Plate - Left		1
66	Hexagon Bolt	M8X20	2
67	Hexagon Bolt	M10X20	10
68	Spacer sleeve		2

PART LIST

NO.	Part Name	Specification	QTY
70	Flat washer	M8	3
71	Hexagon Bolt	M8X16	8
72	Spring Collar		8
73	Barbell Hanger		1
74	Weight Plate Storage		8
75	Hexagon Bolt	M16X70	8
76	Magnetic Landmine		1
77	Landmine Magnet		1
78	LOGO Plate		1
79	J-Hook Right		1
80	J-Hook Left		1
81	Spotter Arm Right		1
82	Spotter Arm Left		1
83	Bracket L-Shape Floor		4
84	Flat washer	M12	8
85	Nut	M12	4
86	Hexagon Bolt	M12X95	4
87	Close Grip Triang leLandmine Handle		1
88	Hook		2
89	Peg		4
90	Ankle Cuff		2
91	Single Knurled Handle		2
92	Extension Chain		4
93	Tricep Rope		1
94	Revolving Lat Pull Down Bar		1
95	Bodyweight AssistedStrap		1
96	Weight Stack Band Peg Hook		8
97	Mag Pin		4
98	Hexagonalrivet nut	M8	16
99	Square Tube Plug		2
100	LOGO plate		1
101	Hexagon bolt	M4X5	16
102	Elastic retaining rings	M25	2

PART LIST

NO.	Part Name	Specification	QTY
103	Hexagon bolt	M8X35	2
104	Nut	M8X35	2
105	Hexagon socket cap screws	M5X8	2
106	Inner shaft	M17X97	2
107	Spacer sleeve	7X5.2X4	2
108	Hexagon bolt	M8X16	4
109	Nut	M8X16	4
110	Drivepipe	M12XM8.1X26	2
111	Hexagon bolt	M6X35	10
112	Nut	M6X35	10
113	LOGO plate		1
114	Handle	M25X138	2
115	Pulling pin shaft	M25	4
116	Pulling handle	M44	8
117	Pulling spring		8
118	Impact protection sleeve	M16	4
119	Hexagon socket cap screws	M6X10	4
120	Bushing	50-60	4
121	Pulling pin shaft	M18	4
122	LOGO plate		1
123	Spacer sleeve	M16	4
124	Hexagon bolt	M8x60	2
125	Nut	M8x60	2
126	Plastic mat		8
127	Deep groove ball bearing	6005	4
128	LOGO plate		1
129	Deep groove ball bearing	6003	2
130	Positioning pull tab		1
131	Deep groove ball bearing	31900	2
132	Circlip for hole	M22	2
133	Square Tube Plug	50X75X2	2
134	LOGO plate		1
135	Blind rivet	4x10	44
136	Screw-on hexagonal rivet nut	M10	12

PART LIST

NO.	Part Name	Specification	QTY
137	Hexagonal rivet nut	M6	2
138	Conical buffer pad		2
139	Hex socket flat head screw	M6X20	2
140	flat washer	M6	2
141	LOGO plate		1
142	Nut	M40	6
143	Rubber mat		6
144	Cross-slot small countersunk screw	M4X10	18
145	Hanging ring		1
146	Nut	M8	2
147	Handle release pin of umbrella	M12XM20X40	2
148	Plastic sleeve		4
149	Elastic collar	35	4
150	Nut	M12	2
151	Plastic sleeve		8
152	Plug		2
153	Barbell holder		4
154	Barbell tube		4
155	Rubber retaining ring		12
156	Decorative aluminum cover		4
157	Hexagon blot	M10X25	20
158	Pulley adjustment plate		4
159	Elastic collar	45	8
160	Safety interval sleeve		2
161	Safety handle		2
162	linear bearing		6
163	Deep groove ball bearing		4
164	Barbell inner bar		1
165	Barbell aluminum bar		1
166	Hexagon bolt	M6X16	4
167	Spring washer	M6X16	4
168	Left hook		1
169	Right hook		1
170	Safety interval sleeve		2

PART LIST

NO.	Part Name	Specification	QTY
171	Hexagon bolt	M10X16	2
172	Barbell sleeve		2
173	Aluminum innerretaining ring	M60	2
174	Needle roller bearing		4
175	Barbell bar end cap		2
176	Rubberretaining ring		2
177	Elastic collar		2
178	Hooked gasket		1
179	Hexagon bolt	M6X12	4
180	Decorative aluminum cover		8
181	Landmine		1
182	Reduction sleeve		1
183	Powder sleeve		2
184	Universal U-shaped part	M6X16	1
185	Deep groove ball bearing	6001	1
186	Universal joint	M25	1
187	Universal gasket		1
188	Spring washer		1
189	Universal gasket	M8	1
190	Inner shaft	M15.8	1
191	Elastic collar		1
192	Nut	M16	2
193	Magnetic coupling shaft	M28	1
194	Strong magnet		1
195	Hexagon bolt	M5X10	1
196	LOGO plate	M44	1
197	Hook plate		4
200	Long rubber sheet		2
201	Laminated rubber sheet		2
202	Hexagon bolt	M6X16	46
203	Short spacer plate		2
204	Rubber mat		2
205	Decorative plate		2
206	Hexagon bolt		1

PART LIST

NO.	Part Name	Specification	QTY
207	Traction shaft		1
208	Pull the handle plate		2
209	Pull the handle shaft		2
210	Large hook plate		1
211	Large puller handle retaining ring		2
212	Hexagon bolt	M6X6	6
213	Short spacer plate		4
214	Long rubber sheet		2
215	Short spacer plate		2

TROUBLE SHOOTING

Weight stack top plate and guide rod assembly is floating/not resting on weight stack plate:

The cable tension needs adjusting. There are 2 adjustment places. Either adjust the pulley that goes into weight stack by screwing it in/out of the top plate or by choosing a different bolt hole on the floating pulley. Refer to Step 7.

The base unit is not square or the smith machine is not resting on both sides:

Loosen all nuts and bolts and then retighten from the bottom up.

What if my Smith Machine is not smooth or drags on one side:

Ensure the unit is level and square. Clean and/or lubricate guide rods. Ensure guide rods are not bent or received any damage.

The cables are not smooth on one or both sides:

Ensure cables are ONLY touching the pulley wheels. Be sure cable routing is correct so that it is not going over or under bolts or the frame.

Ensure pulley wheels are not overtightened, and each wheel is able to move freely. Add lubrication to the bearings if necessary.

WARRANTY INFO

For warranty information please contact the dealer nearest to you.



<https://www.forceusa.com/locator>

FORCE **USA**

forceusa.com